

CABALA

An Overview

(For Initiates Only)

by

Campbell M Gold

(1992)

--()--

Contents

Introduction.....	2
The Smaragdine Tablet of Hermes.....	2
The General Cosmic Planes	3
O.E.V Planes.....	3
Veritas and Cabalism	4
Ain Soph Aur	4
The Sephiroth.....	5
The Tree of Life - Basic Model	6
Tree of Life - Veritas.....	7
Tree of Life - Jewish Tradition.....	8
The Tree of Life (Veritas Definitions	9
The Tree of Life (Veritas Definitions) - Cont	9
The Tree of Life - Veritas Numbering & Legends	11
The Tree of Life - Jewish Numbering & Legends.....	12
The Tree of Life - Veritas Sephiroth Definition	13
The Tree of Life - Detailed Sephiroth Definition.....	14
The First Sephirah - Kether	14
The Second Sephirah - Chokmah	14
The Third Sephirah - Binah	15
The Fourth Sephirah - Chesed.....	16
The Fifth Sephirah - Geburah.....	17
The Sixth Sephirah - Tipareth	17
The Seventh Sephirah - Netzach	18
The Eighth Sephirah - Hod	19
The Ninth Sephirah - Yesod	19
The Tenth Sephirah - Malkuth.....	20
The Tarot Trumps	22
The Tarot Suits - An Overview.....	22
The Suits - Veritas.....	23
The Suits - Cabala	23
The Trumps and The Paths of The Tree of Life	24
The Tree of Life - Trump Names.....	26
The Tree of Life - Trump Numbers	27
The Golden Dawn Tarot.....	28
The Trumps	28
The Four Aces.....	33
The Sixteen Court Cards	34
The Suit of Pentacles	37
The Suit of Cups.....	39
The Suit of Wands	40
The Suit of Swords	42
The Four Worlds	44

The Tree of Life - 4 Veritas Worlds	45
The Tree of Life - 4 Jewish Worlds	46
The Tree of Life - Lightning Flash	47
The Tree of Life - Great Octave of Creation	48
The Tree of Life - Astrology.....	49

--()--

Introduction

The following material is for initiates of the Ordo ex Veritas; and links the cabala symbolism to the teachings of the oev. He who hath eyes will see... thus it is... and thus shall it be...

Cabala (Hebrew form *Qabbalah* - "to receive"; literally, "the received or traditional lore".

Cabala is the specific term for the esoteric or mystic doctrine concerning God and the universe, which is asserted to have come down as a revelation to "the elect" from a remote past, and understood and preserved only by a "privileged few".

The Hebrew Cabalists referred the highest and most abstract ideas to the Emanations of Deity or Sephiroth. Consequently, with reference to the cabala, there are ten Sephira, and when these are correctly arranged in a particular manner they form The Tree of Life, which is a/the key to unlock all the "powers and mysteries of the universe".

--()--

The Smaragdine Tablet of Hermes

The Cabalistic Archetype is summarized in The Smaragdine Tablet of Hermes:

True, without error, certain and most true; that which is above is as that which is below, and that which is below is as that which is above, for performing the miracle of the One Thing; and as all things were from one, by the meditation of one, so all things arose from this one thing by adoption; the father of it is the sun, the mother of it is the moon; the wind carries it in its belly; the nurse thereof is the earth. This is the father of all perfection, or the consummation of the whole world. The power of it is integral if it be turned into earth. Thou shalt separate the earth from the fire, the subtle from the gross, gently with much sagacity; it ascends from earth to heaven, and again descends to earth: and receives the strength of the superiors and of the inferiors - so thou hast the glory of the whole world; therefore let all obscurity flee before thee. This is the strongest fortitude of all fortitudes, overcoming every subtle and penetrating every solid thing. So the world was created. Hence were all wonderful adaptations of which this is the manner. Therefore am I called Thrice Greatest Hermes, having the three parts of the philosophy of the whole world. That which I have written is consummated concerning the operation of the sun.

(Smaragdine Tablet of Hermes - The Emerald Tablet)

--()--

The General Cosmic Planes

To understand any esoteric system it is necessary to map the universal planes wherein it resides and refers:

Plane	Occult System	Cabalistic System	Enocian System	Enocian Body
1	Divine	Three Planes of the Divine and Formless Spiritual World	Divine	Divine Body
2	Upper Consciousness/Spiritual (Abstract Spirit)		Two Spiritual Planes	Spiritual Body
3	Lower Consciousness/Spiritual (Concrete Spirit)			
THE GREAT OUTER ABYSS				
4	Upper Mental (Abstract Mind)	Archetypal	Two Mental Planes	Mental Body
5	Lower Mental (Concrete Mind)	Intellectual (Creative)		
6	Etheric	Substantial (Formative)	Astral	Astral Body
7	Physical	Physical	Physical	Physical Body

--()--

O.E.V Planes

Plane	Sphere	Element	Consciousness	Body
Divine	ULFE Universal Oneness	Divine (Caelestis)	Divine	Divine (Crystallised)
Veil of Non-Existence				
4	Consciousness	Air (Aurae)	Spiritual	Conscious
Mental Veil				
3	Mental	Fire (Incendium)	Intellectual	Mental
Astral Veil				
2	Etheric	Water (Aqua)	Emotional	Etheric
Etheric Veil (Akashic Record)				
1	Physical	Earth (Terra)	Physical	Physical
0	Sub-Physical	Sub-Physical (Solidum)	Sub-Physical	Sub-Physical

--()--

Veritas and Cabalism

Plane	Veritas System	Element	Cabalistic	Cabalistic
Divine	ULFE Universal Oneness	Divine (Caelestis)	Or En Soph (Ain Soph Aur) The Limitless Light of the Unmanifest (Three Veils)	
Veil of Non-Existence				
4	Spirit	Air (Aurae)	Atziluth (Azilut)	Archetypal World
Spirit Veil				
3	Astral	Fire (Incendium)	Briah (Beriah)	Creative World
Astral Veil				
2	Etheric	Water (Aqua)	Yetzirah (Yizerah)	Formative World
Etheric Veil (Akashic Records)				
1	Physical	Earth (Terra)	Assiah (Asiyyah)	Material World
0	Sub-Physical (Solidum)			

--()--

Ain Soph Aur

Ain - The 'Negative' - Meaning the 'No-Thing' - 'Is-Not'
 Soph - 'Limitless'
 Aur - 'Light'

Ain Soph Aur - The Limitless Light (The No-Thing)

World	Type	Tetragramaton	Element	Tarot Suit
Atziluth	Formation	Yod	Fire	Wands
Briah	Creation	Heh	Water	Cups
Yetzira	Archetypal	Vau	Air	Swords
Assiah	Material	Heh (Final)	Earth	Pentacles

--()--

The Sephiroth

Sephira	VeritasName	Power	VeritasDefinition
1	Kether	K-Th-R	The Crown
2	Chokmah	Ch-K-M-H	Wisdom
3	Binah	B-I-N-H	Understanding
	Daath	D-A-A-Th	Knowledge
4	Chesed*	Ch-S-D	Mercy
5	Geburah*	G-B-U-R-H	Severity
6	Tipareth	Th-Ph-A-R-Th	Beauty
7	Netzach	N-Tz-Ch	Victory
8	Hod	H-O-D	Glory
9	Yesod	Y-S-O-D	The Foundation
10	Malkuth	M-L-K-U-Th	The Kingdom

* Chesed - is also known as "Gedulah"

* Geburah - is also known as "Pahad"

Sephira	Veritas Tradition	Jewish Tradition	Jewish Definition
1	Kether	Keter	Crown
2	Chokmah	Hokhmah	Wisdom
3	Binah	Binah	Understanding
	Daath	Daat	Knowledge
4	Chesed*	Hesed	Mercy
5	Geburah*	Gevurah	Judgement
6	Tipareth	Tiferet	Beauty
7	Netzach	Nezah	Eternity
8	Hod	Hod	Reverberation
9	Yesod	Yesod	Foundation
10	Malkuth	Malkhut	Kingdom
	Qliphoth		Harlot

* Chesed - is also known as "Gedulah"

* Geburah - is also known as "Pahad"

--()--

The Tree of Life - Basic Model

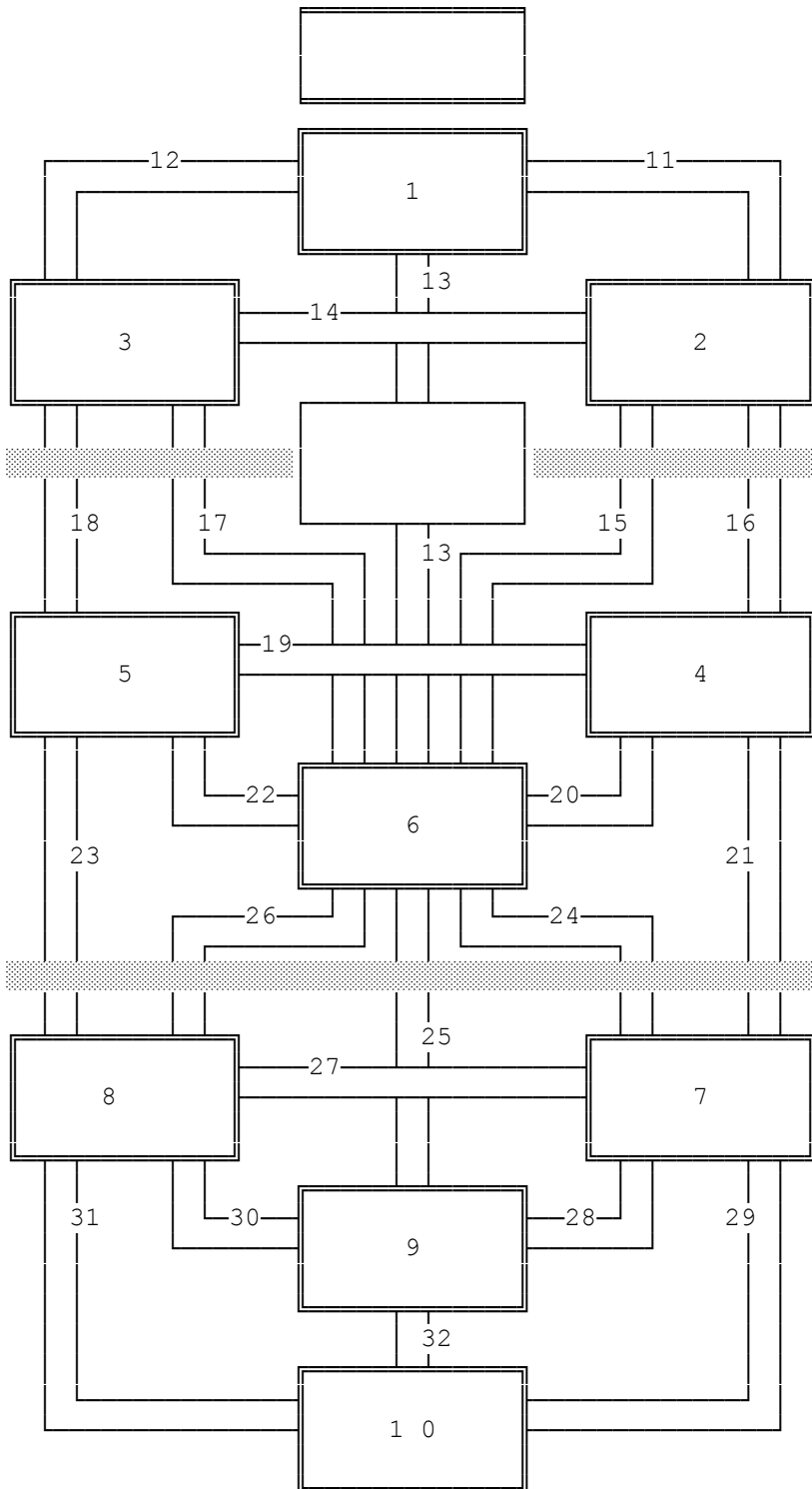

--()--

Tree of Life - Veritas

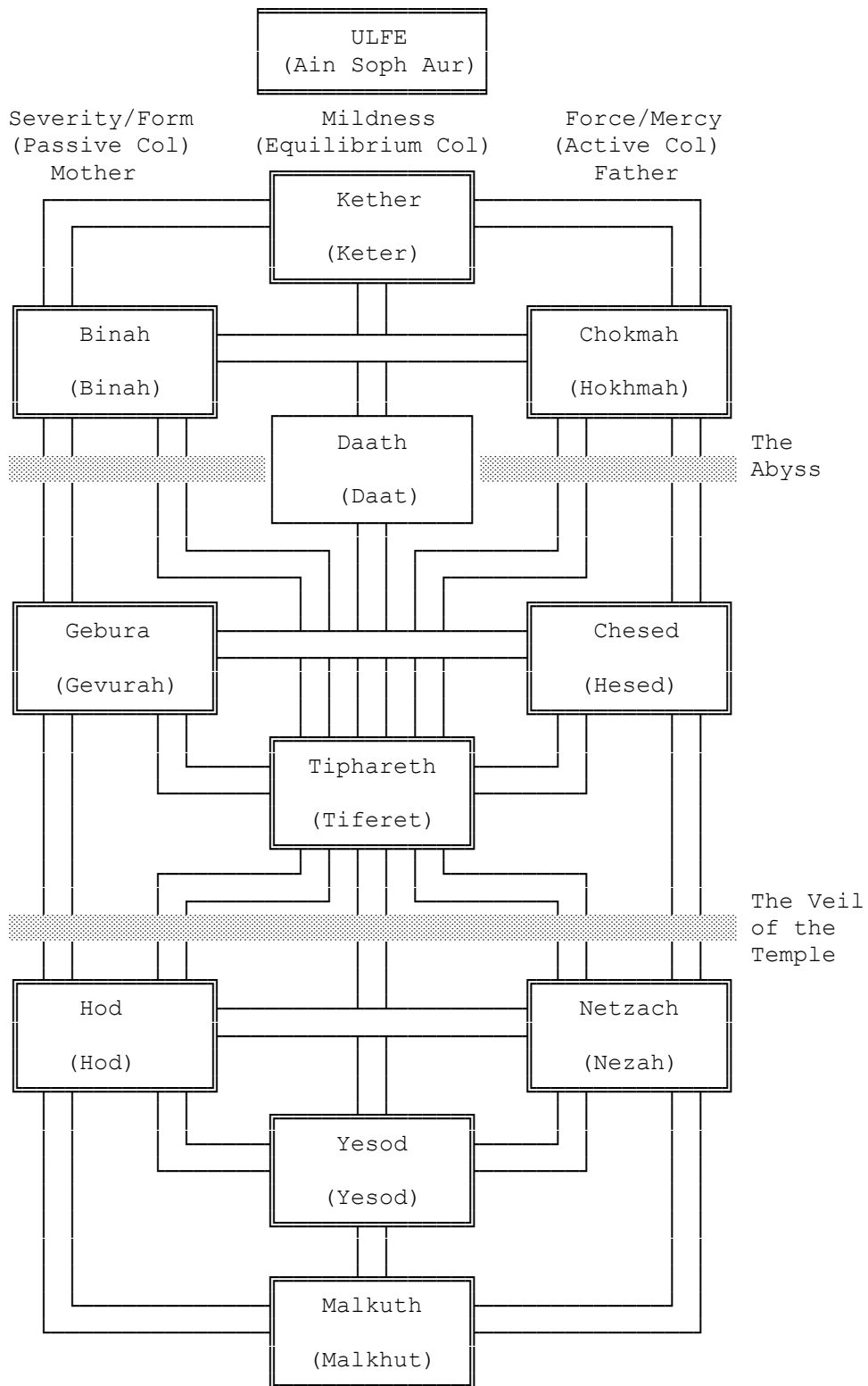

--()--

Tree of Life - Jewish Tradition

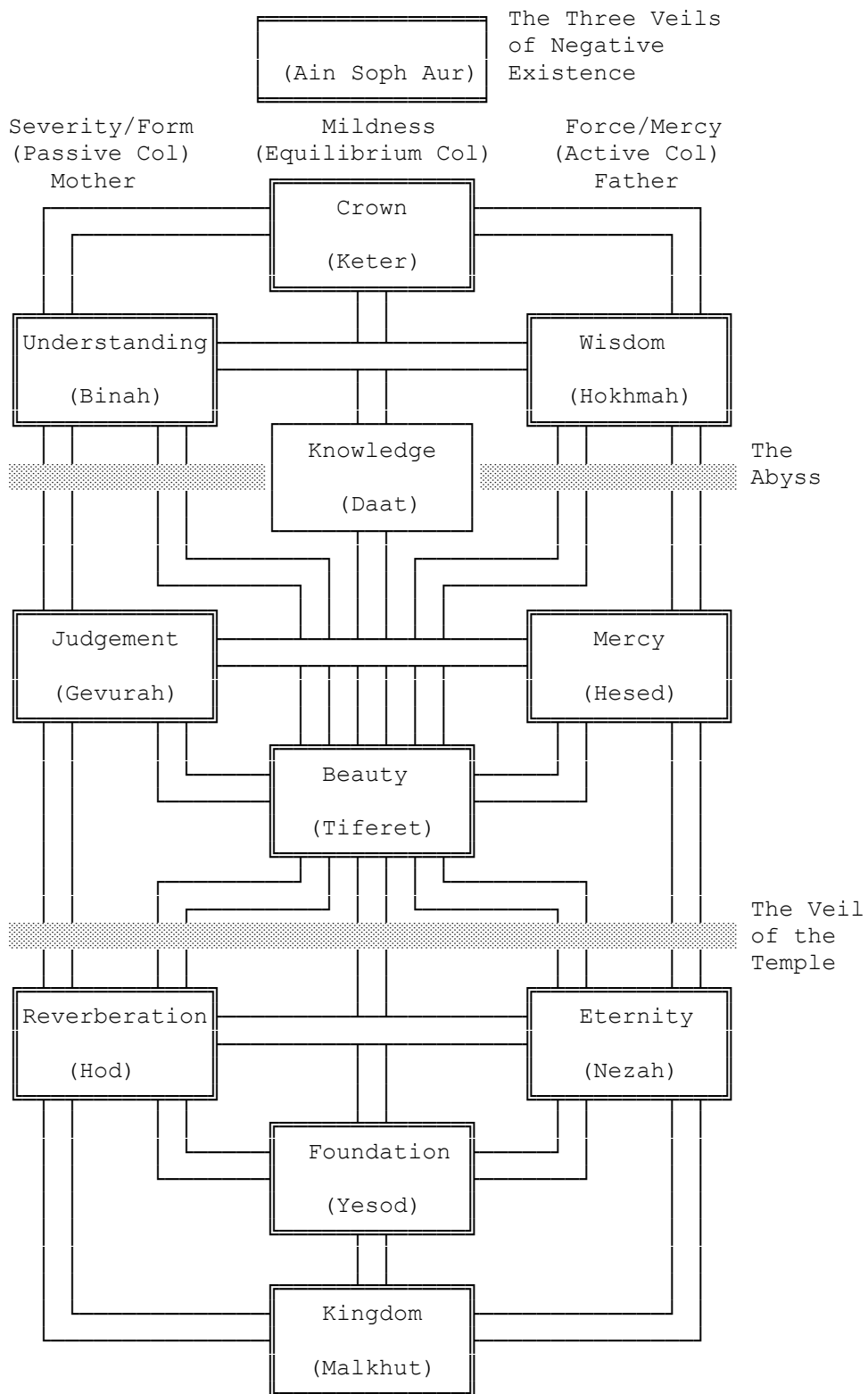

--()--

The Tree of Life (Veritas Definitions)

Sephira	Name	Meaning	Represents	Position
1	Kether	The Crown	Premium Mobile	1M
2	Chokmah	Wisdom	The Zodiac	2R
3	Binah	Understanding	Saturn	2L
	Daath	Knowledge		2.5M
4	Chesed*	Mercy	Jupiter	3R
5	Geburah*	Strength	Mars	3L
6	Tipareth	Beauty	Sun	4M
7	Netzach	Victory	Venus	5R
8	Hod	Splendour	Mercury	5L
9	Yesod	Foundation	Moon	6M
10	Malkuth	Kingdom	Elements	7M
Qlipoth	Harlot			8M

* Chesed - is also known as "Gedulah"

* Geburah - is also known as "Pahad"

--()---

The Tree of Life (Veritas Definitions) - Cont

Path No (Waite)	Hebrew Letter	Correspondence	Connecting	Tarot Trump
11	Aleph	Air	1 - 2	0
12	Beth	Mercury	1 - 3	I
13	Gimel	Luna	1 - 6	II
14	Daleth	Venus	2 - 3	III
15	He	Aries	2 - 6	IV
16	Vau	Taurus	2 - 4	V
17	Zayin	Gemini	3 - 6	VI
18	Cheth	Cancer	3 - 5	VII
19	Teth	Leo	4 - 5	VIII
20	Yod	Virgo	4 - 6	IX
21	Kaph	Jupiter	4 - 7	X
22	Lamed	Libra	5 - 6	XI
23	Mem	Water	5 - 8	XII
24	Nun	Scorpio	6 - 7	XIII
25	Samekh	Sagittarius	6 - 9	XIV
26	Ayin	Capricorn	6 - 8	XV
27	Pe	Mars	7 - 8	XVI
28	Tzaddi	Aquarius	7 - 9	XVII

Path No (Waite)	Hebrew Letter	Correspondence	Connecting	Tarot Trump
29	Qoph	Pisces	7 - 10	XVIII
30	Resh	Sol	8 - 9	XIX
31	Shin	Fire	8 - 10	XX
32	Tau	Saturn	9 - 10	XXI
31 Bis		Spirit		
31 Bis		Earth		

* Chesed - is also known as "Gedulah"

* Geburah - is also known as "Pahad"

--()--

The Tree of Life - Veritas Numbering & Legends

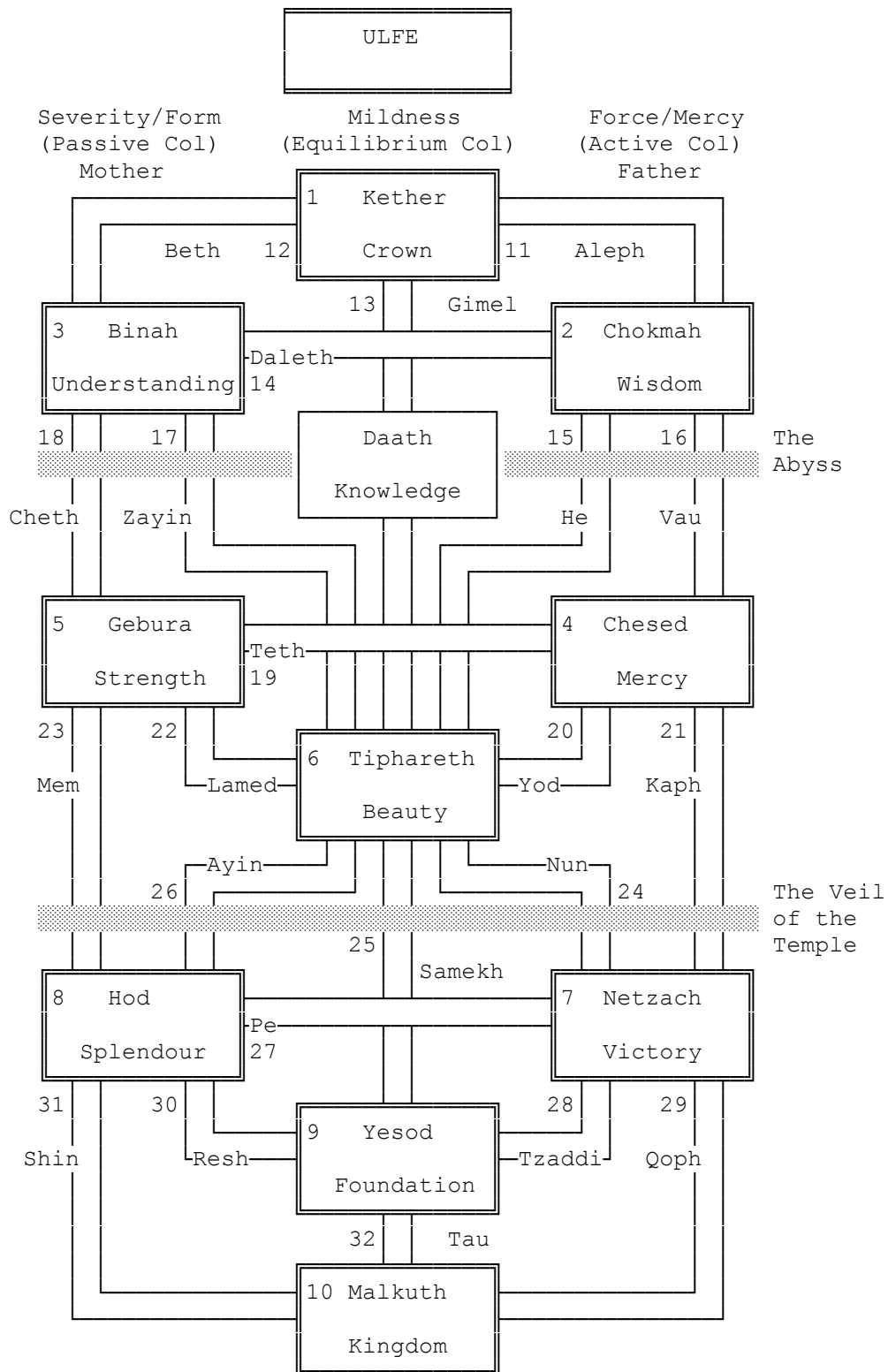

--()--

The Tree of Life - Jewish Numbering & Legends

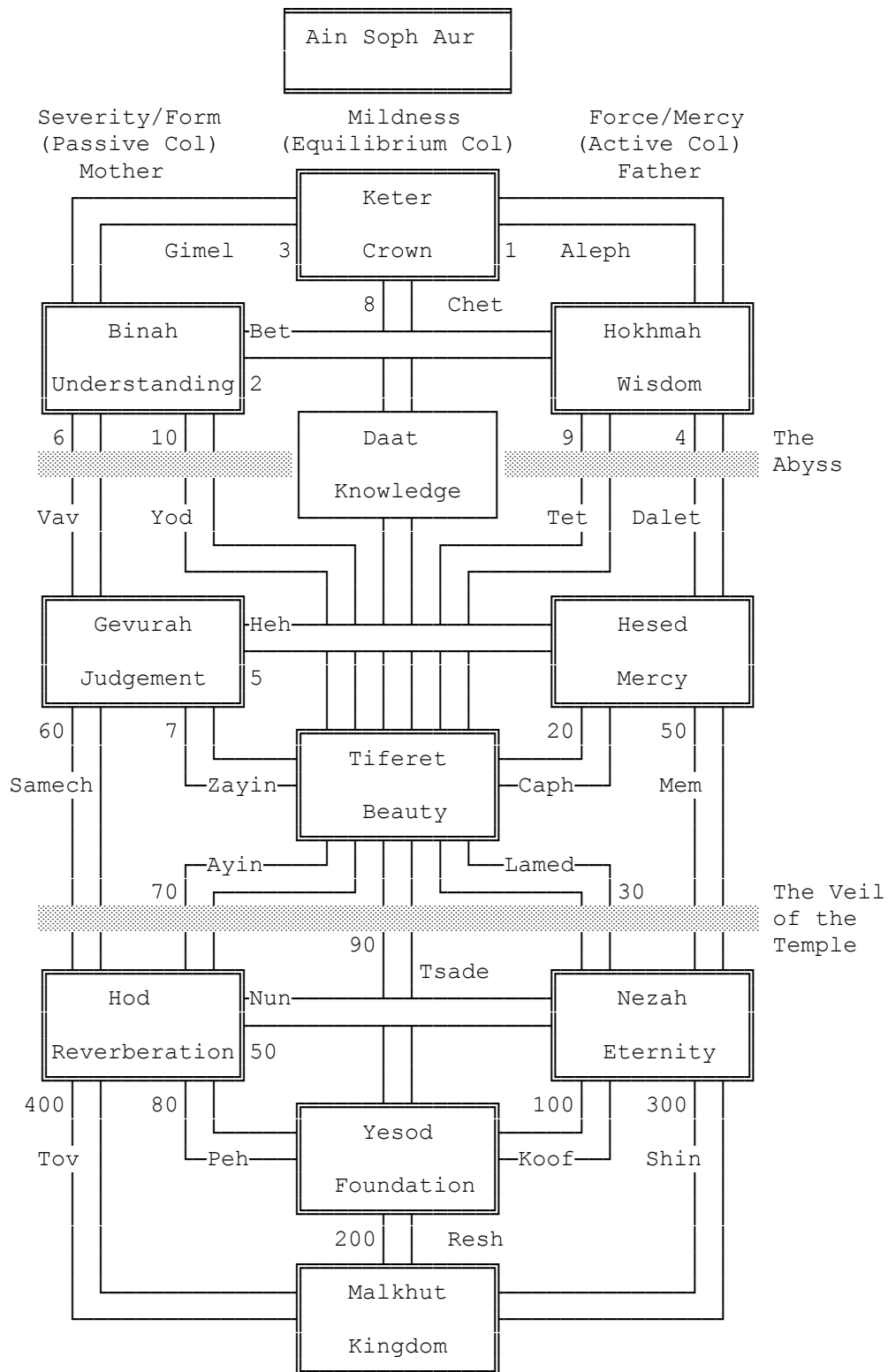

--()--

The Tree of Life - Veritas Sephiroth Definition

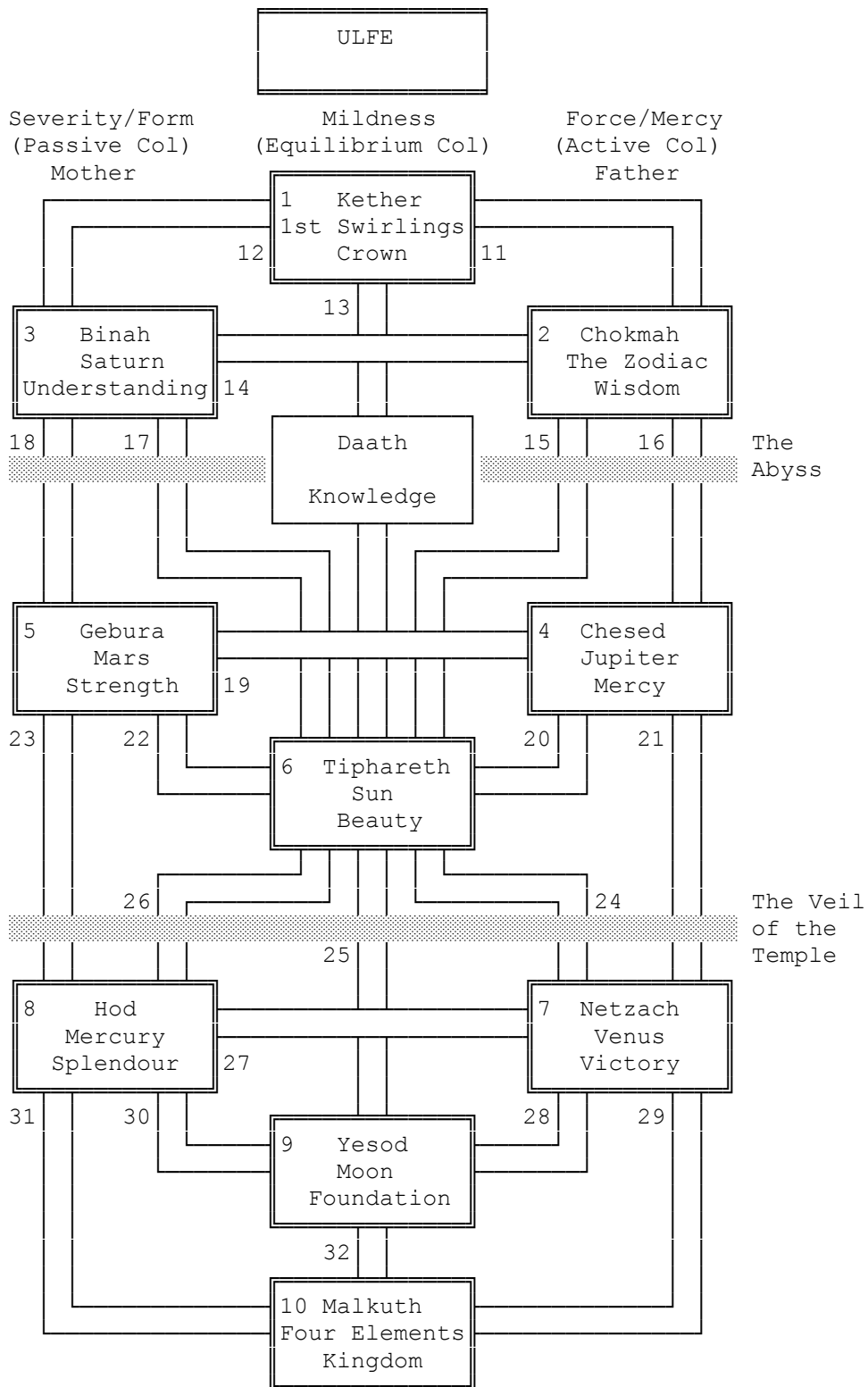

--()--

The Tree of Life - Detailed Sephiroth Definition

The First Sephirah - Kether	
Title	Kether, the Crown. (Hebrew spelling: Kaph, Tau, Resh.) (The Matrix. The Door To/From The Unmanifest.)
Magical Image	An ancient bearded king seen in profile.
Situation On The Tree	At the head of the Pillar of Equilibrium in the Supernal Triangle.
Yetziratic Text	The First Path is called the Admirable or Hidden Intelligence because it is the Light giving the power of comprehension of the First Principle, which hath no beginning. And it is the Primal Glory, because no created being can attain to its essence.
Titles Given	Existence of Existences. Concealed of the Concealed. Ancient of Ancients. Ancient of days. The Primordial Point. The Point within the Circle. The Most High. The Vast Countenance. The White Head. The Head which is not. Macroprosopos. Amen. Lux Occulta. Lux Interna. He. The Inscrutable Height.
God-Name	Ehyeh. (Av - 'I Am')
Archangel	Metatron. Angel of the Presence.
Order of Angels	Holy living creatures. Chayyoth ha-Qodesh.
Mundane Chakra	Reshith ha-Gilgulim. Primum Mobile. First Swirlings.
Spiritual Experience	Union with God.
Virtue	Completion of the Great Work.
Vice	_____
Correspondence In The Microcosm	The Cranium. The Sah. Yechidah. The Divine Spark. The Thousand-Petalled Lotus.
Symbols	The point. The crown. The swastika.
Tarot Cards	The Four Aces. Ace of Wands: Root of the Powers of Fire. Ace of Cups: Root of the Powers of Water. Ace of Swords: Root of the Powers of Air. Ace of Pentacles: Root of the Powers of Earth.
Colour In Atziluth	Brilliance.
Colour In Briah	Pure white brilliance.
Colour In Yetzirah	Pure white brilliance
Colour In Assiah	White, flecked gold.

--()--

The Second Sephirah - Chokmah	
Title	Chokmah, Wisdom. (Hebrew spelling: Cheth, Kaph, Mem, He.)
Magical Image	A bearded male figure.
Situation On The Tree	At the head of the Pillar Mercy in the Supernal Triangle.
Yetziratic Text	The Second Path is called the Illuminating Intelligence. It is the Crown of Creation, the Splendour of Unity, equalling it. It is exalted above every head, and is named by Cabalists the Second Glory.

The Second Sephirah - Chokmah	
Titles Given	Power of Yetzirah. Av. Abba. The Supernal Father. Tetragrammaton. Yod of Tetragrammaton.
God-Name	Jehovah.
Archangel	Raziel, Secret, or Herald, of God.
Order of Angels	Ophanim, wheels.
Mundane Chakra	Mazzaloth, the Zodiac.
Spiritual Experience	The Vision of God face to face.
Virtue	Devotion.
Vice	_____
Correspondence In The Microcosm	The left side of the face.
Symbols	The Lingam. The Phallus. The Yod of Tetragrammaton. The Inner Robe of Glory. The Standing-stone. The Tower. The Uplifted Rod of Power. The Straight Line.
Tarot Cards	The Four Twos. Two of Wands: Domination. Two of Cups: Love. Two of Swords: Peace restored. Two of Pentacles: Harmonious change
Colour In Atziluth	Pure soft blue.
Colour In Briah	Grey.
Colour In Yetzirah	Pearl-grey, iridescent.
Colour In Assiah	White flecked with red, blue, and yellow.

--()--

The Third Sephirah - Binah	
Title	Binah, Understanding, (Hebrew spelling: Beth, Yod, Num, He.)
Magical Image	A mature woman. A matron.
Situation On The Tree	At the head of the Pillar of Severity in the Supernal Triangle.
Yetziratic Text	The Third Intelligence is called the Sanctifying Intelligence, the Foundation of Primordial Wisdom; it is also called the Creator of Faith, and its roots are in Amen. It is the parent of faith, whence faith emanates.
Titles Given	Ama, the dark sterile Mother. Aima, the bright fertile Mother. Kursiya, the Throne. Marah, the Great sea.
God-Name	Jehovah Elohim.
Archangel	Tzaphkiel. Beholder, or Eye, of God.
Order of Angels	Er 'elim, Thrones.
Mundane Chakra	Shabbathai, Saturn.
Spiritual Experience	Vision of Sorrow.
Virtue	Silence.
Vice	Avarice.

The Third Sephirah - Binah	
Correspondence In The Microcosm	The right side of the face.
Symbols	The Yoni. The Kteis. The Vesica Piscis. The cup or chalice. The Outer Robe of Concealment
Tarot Cards	The Four Threes. Three of wands: Established strength. Three of cups: Abundance. Three of swords: Sorrow. Three of pentacles: Material works.
Colour In Atziluth	Crimson.
Colour In Briah	Black.
Colour In Yetzirah	Dark brown.
Colour In Assiah	Grey flecked pink.

--()---

The Fourth Sephirah - Chesed	
Title	Chesed, mercy. (Hebrew spelling: Cheth, Samech, Daleth.)
Magical Image	A mighty crowned and throned king.
Situation On The Tree	In the centre of the Pillar of Mercy.
Yetziratic Text	The Fourth Path is called the cohesive or Receptive Intelligence because it contains all the holy Powers, and from it emanates all the spiritual virtues with the most exalted essences. They emanate one from another by virtue of the Primordial Emanation, the Highest Crown, Kether.
Titles Given	Gedullah. Love. Majesty.
God-Name	El.
Archangel	Tzadkiel. Benevolence of God.
Order of Angels	Chashmallim, Brilliant Ones.
Mundane Chakra	Tzedek, Jupiter.
Spiritual Experience	Vision of love.
Virtue	Obedience.
Vice	Bigotry. Hypocrisy. Gluttony. Tyranny.
Correspondence In The Microcosm	The left arm.
Symbols	The solid figure. Tetrahedron. Pyramid. Equal-armed cross. Orb. Wand. Sceptre. Crook.
Tarot Cards	The Four Fours. Four of wands: Perfected work. Four of cups: Pleasure. Four of swords: Rest from strife. Four of pentacles: Earthly power.
Colour In Atziluth	Deep violet.
Colour In Briah	Blue.
Colour In Yetzirah	Deep purple.
Colour In Assiah	Deep azure, flecked yellow.

--()--

The Fifth Sephirah - Geburah	
Title	Geburah, Strength, Severity. (Hebrew spelling: Gimal, Beth, Vav, Resh, He.)
Magical Image	A mighty warrior in his chariot.
Situation On The Tree	In the centre of the Pillar of Severity.
Yetziratic Text	The Fifth Path is called the Radical Intelligence because it resembles unity, uniting itself to Binah, Understanding, which emanates from the primordial depths of Chokmah, Wisdom.
Titles Given	Din: Justice. Pachad: Fear.
God-Name	Elohim Gibbor.
Archangel	Chamael. Burner of God.
Order of Angels	Seraphim, Fiery Serpents.
Mundane Chakra	Ma'adim, Mars.
Spiritual Experience	Vision of Power.
Virtue	Energy. Courage.
Vice	Cruelty. Destruction.
Correspondence In The Microcosm	The Right Arm.
Symbols	The Pentagon. The Five-Petalled Tudor Rose. The Sword. The Spear. The Scourge. The Chain.
Tarot Cards	The Four Fives. Five of Wands: Strife. Five of Cups: Loss in Pleasure. Five of Swords: Defeat. Five of Pentacles: Earthly Trouble
Colour In Atziluth	Orange.
Colour In Briah	Scarlet Red.
Colour In Yetzirah	Bright Scarlet.
Colour In Assiah	Red, flecked with Black.

--()--

The Sixth Sephirah - Tipareth	
Title	Tiphareth, Beauty. (Hebrew spelling: Tav, Pe, Aleph, Resh, Tav.)
Magical Image	A majestic king. A child. A sacrificed god.
Situation On The Tree	In the centre of the Pillar of Equilibrium.
Yetziratic Text	The Sixth Path is called the Mediating Intelligence, because in it are multiplied the influxes of the Emanations; for it causes that influence to flow into all the reservoirs of the blessings with which they themselves are united.
Titles Given	Zeir Anpin, the Lesser Countenance. Melekh, the King. Adam. The Son. The Man.
God-Name	Tetragrammaton Eloah Va Daath.

The Sixth Sephirah - Tipareth	
Archangel	Raphael. Healing of God.
Order of Angels	Melachim, Kings.
Mundane Chakra	Shemesh, the Sun.
Spiritual Experience	Vision of the harmony of things. Mysteries of the Crucifixion.
Virtue	Devotion to the Great Work.
Vice	Pride.
Correspondence In The Microcosm	The breast.
Symbols	The Rose Cross. The Calvary Cross. The truncated pyramid. The cube.
Tarot Cards	The Four Sixes. Six of Wands: Victory. Six of Cups: Joy. Six of Sword: Earned success. Six of Pentacles: Material success.
Colour In Atziluth	Clear rose-pink.
Colour In Briah	Yellow.
Colour In Yetzirah	Rich salmon-pink.
Colour In Assiah	Golden amber.

--()--

The Seventh Sephirah - Netzach	
Title	Netzach, Victory. (Hebrew spelling: Nun, Tzaddi, Cheth.)
Magical Image	A beautiful naked woman.
Situation On The Tree	At the foot of the Pillar of Mercy.
Yetziratic Text	The Seventh Path is called the Occult Intelligence because it is the refulgent splendour of the intellectual virtues which are perceived by the eyes of the intellect and the contemplations of faith.
Titles Given	Firmness.
God-Name	Jehovah, Tseva'oth, the Lord of Hosts.
Archangel	Haniel, Grace of God.
Order of Angels	Elohim, Gods.
Mundane Chakra	Nogah, Venus.
Spiritual Experience	Vision of beauty triumphant.
Virtue	Unselfishness.
Vice	Unchastity. Lust.
Correspondence In The Microcosm	Loins, hips, and legs.
Symbols	Lamp and girdle. The rose.
Tarot Cards	The Four Sevens. Seven of Wands: Valour. Seven of Cups: Illusory success. Seven of Swords: Unstable effort. Seven of Pentacles: Success unfulfilled.

The Seventh Sephirah - Netzach	
Colour In Atziluth	Amber.
Colour In Briah	Emerald
Colour In Yetzirah	Bright yellowish green.
Colour In Assiah	Olive, flecked with gold

--()---

The Eighth Sephirah - Hod	
Title	Hod, Glory. (Hebrew spelling: He, Vav, Daleth.)
Magical Image	An hermaphrodite.
Situation On The Tree	At the foot of the pillar of Severity.
Yetziratic Text	The Eighth Path is called the Absolute or Perfect Intelligence because it is the mean of the Primordial, which has no root by which it can cleave or rest, save in the hidden places of Gedulah, from which emanates its proper essence.
Titles Given	Splendor or Glory
God-Name	Elohim Tseva'oth, the God of Hosts.
Archangel	Michael, Like unto God.
Order of Angels	Bene Elohim, the Sons of the Gods.
Mundane Chakra	Kokhav, Mercury.
Spiritual Experience	Vision of Splendour.
Virtue	Truthfulness.
Vice	Falsehood. Dishonesty.
Correspondence In The Microcosm	Loins and Legs.
Symbols	Names and Versicles and Apron.
Tarot Cards	The Four Eights.Eight of Wands: Swiftmess.Eight of Cups: Abandoned success.Eight of Swords: Shortened force.Eight of Pentacles: Prudence.
Colour In Atziluth	Violet-purple.
Colour In Briah	Orange.
Colour In Yetzirah	Russet-red.
Colour In Assiah	Yellowish black, flecked with white.

--()---

The Ninth Sephirah - Yesod	
Title	Yesod, the Foundation. (Hebrew spelling: Yod, Samech, Vav, Daleth.)
Magical Image	A handsome naked man, very strong.
Situation On The Tree	Towards the base of the Pillar of Equilibrium.

The Ninth Sephirah - Yesod	
Yetziratic Text	The Ninth Path is called the Pure Intelligence because it purifies the Emanations. It proves and corrects the designing of their representations, and disposes the unity which are designed without diminution or division.
Titles Given	The Receptacle of the Emanations
God-Name	Shaddai El Chai, the Almighty Living God.
Archangel	Gabriel, Strong man, or Hero, of God.
Order of Angels	Keruvim, the Strong.
Mundane Chakra	Levanah, the Moon.
Spiritual Experience	Vision of the Machinery of the Universe.
Virtue	Independence.
Vice	Idleness.
Correspondence In The Microcosm	Reproductive organs.
Symbols	The Perfumes and sandals.
Tarot Cards	The Four Nines.Nine of Wands: Great strength.Nine of Cups: Material happiness.Nine of Sword: Despair and cruelty.Nine of Pentacles: Material gain.
Colour In Atziluth	Indigo.
Colour In Briah	Violet.
Colour In Yetzirah	Very dark purple.
Colour In Assiah	Citrine, flecked with azure.

--()--

The Tenth Sephirah - Malkuth	
Title	Malkuth, the Kingdom. (Hebrew spelling: Mem, Lamed, Kaph, Vav, Tav.)
Magical Image	A young woman, crowned and throned.
Situation On The Tree	At the base of the pillar of Equilibrium.
Yetziratic Text	The Tenth Path is called the Resplendent Intelligence because it is exalted above every head and sits upon the Throne of Binah. It illuminates the splendours of all the Lights, and causes an influence to emanate from the Prince of Countenances, the Angel of Kether.
Titles Given	The Gate. The Gate of Death. The Gate of the Shadow of Death. The Gate of Tears. The Gate of Justice. The Gate of Prayer. The Gate of the Daughter of the Mighty Ones. The Gate of the Garden of Eden. The Inferior Mother. Malkah, the Queen. Kallah, the Bride. The Virgin.
God-Name	Adonai Melekh or Adon ha-Arets.
Archangel	Sandalphon.
Order of Angels	Ishim, Souls of Fire.
Mundane Chakra	Olam ha-Yesodoth, Sphere of the Elements.

The Tenth Sephirah - Malkuth	
Spiritual Experience	Vision of the Holy Guardian Angel.
Virtue	Discrimination.
Vice	Avarice. Inertia.
Correspondence In The Microcosm	The feet. The anus.
Symbols	Altar of the double cube. The Equal-armed cross. The magic circle. The triangle of art.
Tarot Cards	The Four Tens. Ten of Wands: Oppression. Ten of Cups: Perfected Success. Ten of Swords: Ruin. Ten of Pentacles: Wealth.
Colour In Atziluth	Yellow.
Colour In Briah	Citrine, olive, russet, and black.
Colour In Yetzirah	Citrine, olive, russet, and black, flecked with gold.
Colour In Assiah	Black, rayed with yellow.

--()--

The Tarot Trumps

No	French	Waite	Thoth
0	The Fool	The Fool	The Fool
1	The Magician	The Magician	The Magus
2	The Papesse	The High Priestess	The Priestess
3	The Empress	The Empress	The Empress
4	The Emperor	The Emperor	The Emperor
5	The High Priest	The Hierophant	The Hierophant
6	The Lovers	The Lovers	The Lovers
7	The Chariot	The Chariot	The Chariot
8	Justice	Strength	Lust
9	Hermit	The Hermit	The Hermit
10	Wheel of Fortune	Wheel of Fortune	Fortune
11	Strength	Justice	Adjustment
12	The Hanged Man	The Hanged Man	The Hanged Man
13	Death	Death	Death
14	Temperance	Temperance	Art
15	The Devil	The Devil	The Devil
16	The Tower	The Tower	The Tower
17	The Star	The Star	The Star
18	The Moon	The Moon	The Moon
19	The Sun	The Sun	The Sun
20	Judgement	Judgement	The Aeon
21	World	The World	The Universe

--()--

The Tarot Suits - An Overview

ESOTERIC TAROT - THE SUIT OF SWORDS
Represents the VAU-Force TETRAGRAMATON, the element of AIR and the Cabalistic World of Yetzirah. Swords indicate intellect, communication, mental faculties and sometimes strife. This suit is the son, the first offspring of the marriage of the elements represented by the two preceding suits (Wands and Cups).
ESOTERIC TAROT - THE SUIT OF WANDS/STAVES
Represents the YOD-Force of TETRAGRAMATON, the element of FIRE and the Cabalistic World of Atziluth. Wands indicate great energy and dynamic power. They also allude to the Great Masculine Power as the first stimulating spark of energy which begins life and sets everything in motion.

ESOTERIC TAROT - THE SUIT OF CUPS
Represents the HEH-Force of TETRAGRAMATON, the element of WATER and the Cabalistic World of Briah. Cups indicate creativity, fecundity, and pleasure. They refer to the form-building capacity of the Great Feminine Power.
ESOTERIC TAROT - THE SUIT OF PENTACLES/COINS/DISCS
Represents the HEH (final) - Force of TETRAGRAMATON, the element of EARTH and the Cabalistic World of Assiah. Pentacles indicate material or worldly affairs, business or money.

--()--

The Suits - Veritas

Suits	Pentacles	Cups	Wands	Swords
Elements	Earth	Water	Fire	Air
Veritas Worlds	Physical	Etheric	Astral	Mental
YHVH	Heh (Final)	Heh	Yod	Vau

--()--

The Suits - Cabala

Suits	Pentacles	Cups	Wands	Swords
Elements	Earth	Water	Fire	Air
Cabala Worlds	Assiah (Material World)	Briah (Creative World)	Atziluth (World of Pure Spirit)	Yetzirah (Formative World)
Cabala Worlds	Active World	Creative World	Archetypal World	Formative World
Cabala YHVH	Heh (Final)	Heh	Yod	Vau

--()--

The Trumps and The Paths of The Tree of Life

The TRUMPS of the TAROT Deck are 22 in number, and are related to the paths connecting the Sephiroth from which they take part of their attributes in the various worlds.

- TRUMP NO. 0 Path No: 11, Aleph, THE FOOL, connecting Kether with Chokmah is the Primum Mobile acting through the Air on the Zodiac.
- TRUMP NO. 1 Path No: 12, Bes, THE MAGICIAN, connecting Kether with Binah is the Crown of Understanding, the beginning of material, the Primum Mobile acting through Mercury or Saturn.
- TRUMP NO. 2 Path No: 13, Gimel, THE HIGH PRIESTESS, connecting Kether with Tiphareth is the Crown of Beauty, the beginning of Beauty, the Primum Mobile acting on the Sun through the Moon.
- TRUMP NO. 3 Path No: 14, Daleth, THE EMPRESS, connecting Chokmah and Binah, is the Wisdom of Understanding, the union of the Powers of Origination and Production, the sphere of the Zodiac acting on Saturn through Venus.
- TRUMP NO. 4 Path No: 15, Heh, THE EMPEROR, connecting Chokmah with Tiphareth is the Wisdom of Sovereignty and Beauty, and the originator of them, the sphere of the Zodiac acting upon the Sun through Aries and initiating Spring.
- TRUMP NO. 5 Path No: 16, Vau, THE HIEROPHANT (THE HIGH PRIEST), connecting Chokmah with Chesed, the Wisdom and fount of Mercury, the sphere of the Zodiac acting on Jupiter through Taurus.
- TRUMP NO. 6 Path No: 17, Zayin, THE LOVERS, connecting Binah and Tiphareth the Understanding and Production of Beauty and Sovereignty, Saturn acting on Sol through Gemini.
- TRUMP NO. 7 Path No: 18, Cheth, THE CHARIOT, connecting Binah and Geburah, is Understanding acting on Severity. Saturn acting on Mars through Cancer.
- TRUMP NO. 8 Path No: 19, Teth, STRENGTH or (FORTITUDE), connecting Chesed and Geburah. Mercy tempering Severity. The Glory of Strength. Jupiter acting on Mars through Leo.
- TRUMP NO. 9 Path No: 20, Yod, THE HERMIT, connecting Chesed and Tiphareth is the Mercy of Beauty, The Magnificence of Sovereignty. Jupiter acting on Sol through Virgo.
- TRUMP NO. 10 Path No: 21, Kaph, THE WHEEL OF FORTUNE, connecting Chesed and Netzach, is the Mercy and Magnificence of Victory. Jupiter acting through Jupiter acting through Jupiter direct on Venus.
- TRUMP NO. 11 Path No: 22, Lamed, JUSTICE, connecting Geburah and Tiphareth, is the Severity of Beauty and Sovereignty. Mars acting on Sol through Libra.
- TRUMP NO. 12 Path No: 23, Mem, THE HANGED MAN, connecting Geburah and Hod is the Severity of Splendour. Execution of Judgement. Mars acting on Mercury through Water.
- TRUMP NO. 13 Path No: 24, Nun, DEATH, connecting Tiphareth and Netzach is the Sovereignty and result of Victory. Sol acting on Venus through Scorpio.
- TRUMP NO. 14 Path No: 25, Samekh, TEMPERANCE, connecting Tiphareth and Yesod, is the Beauty of Firm Basis, the Sovereignty of Fundamental Power. Sol acting on Luna through Sagittarius.
- TRUMP NO. 15 Path No: 26, Ayin, THE DEVIL, connecting Tiphareth and Hod is the Sovereignty and Beauty of Materialism and false splendour. Sol acting on Mercury through Capricorn.

TRUMP NO. 16 Path No: 27, Pe, THE TOWER, connecting Netzach and Hod, is the Victory over Splendour, Avenging Force. Venus acting on Mercury through Mars.

TRUMP NO. 17 Path No: 28, Tsaddi, THE STAR, connecting Netzach and Yesod, is the Victory of Fundamental Strength, Hope. Venus acting on Luna through Aquarius.

TRUMP NO. 18 Path No: 29, Qoph, THE MOON, connecting Netzach and Malkuth, is the Victory of Material Venus acting on the Cosmic elements through Pisces.

TRUMP NO. 19 Path No: 30, Resh, THE SUN, connecting Hod and Yesod, is the Splendour of the Material World. Mercury acting on the Moon through the Sun.

TRUMP NO. 20 Path No: 31, Shin, THE JUDGEMENT, connecting Hod and Malkuth, is the Splendour of the Material World. Mercury acting on the Cosmic Elements through Fire.

TRUMP NO. 21 Path No: 32, Taw, THE WORLD, connecting Yesod and Malkuth, is the Foundation of the Cosmic Elements and of the Material World. Luna acting on the Elements through Saturn.

--()--

The Tree of Life - Trump Names

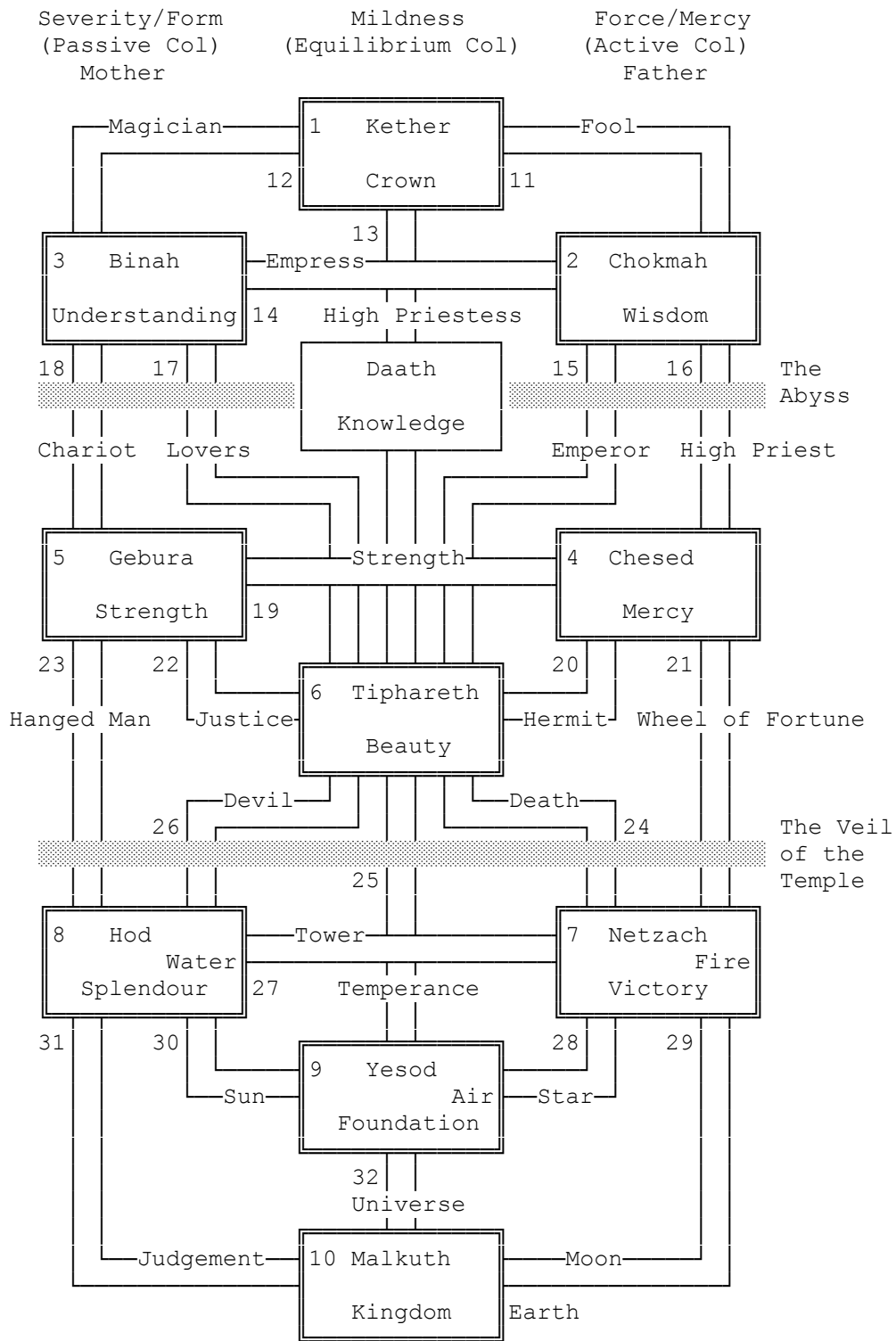

--()--

The Tree of Life - Trump Numbers

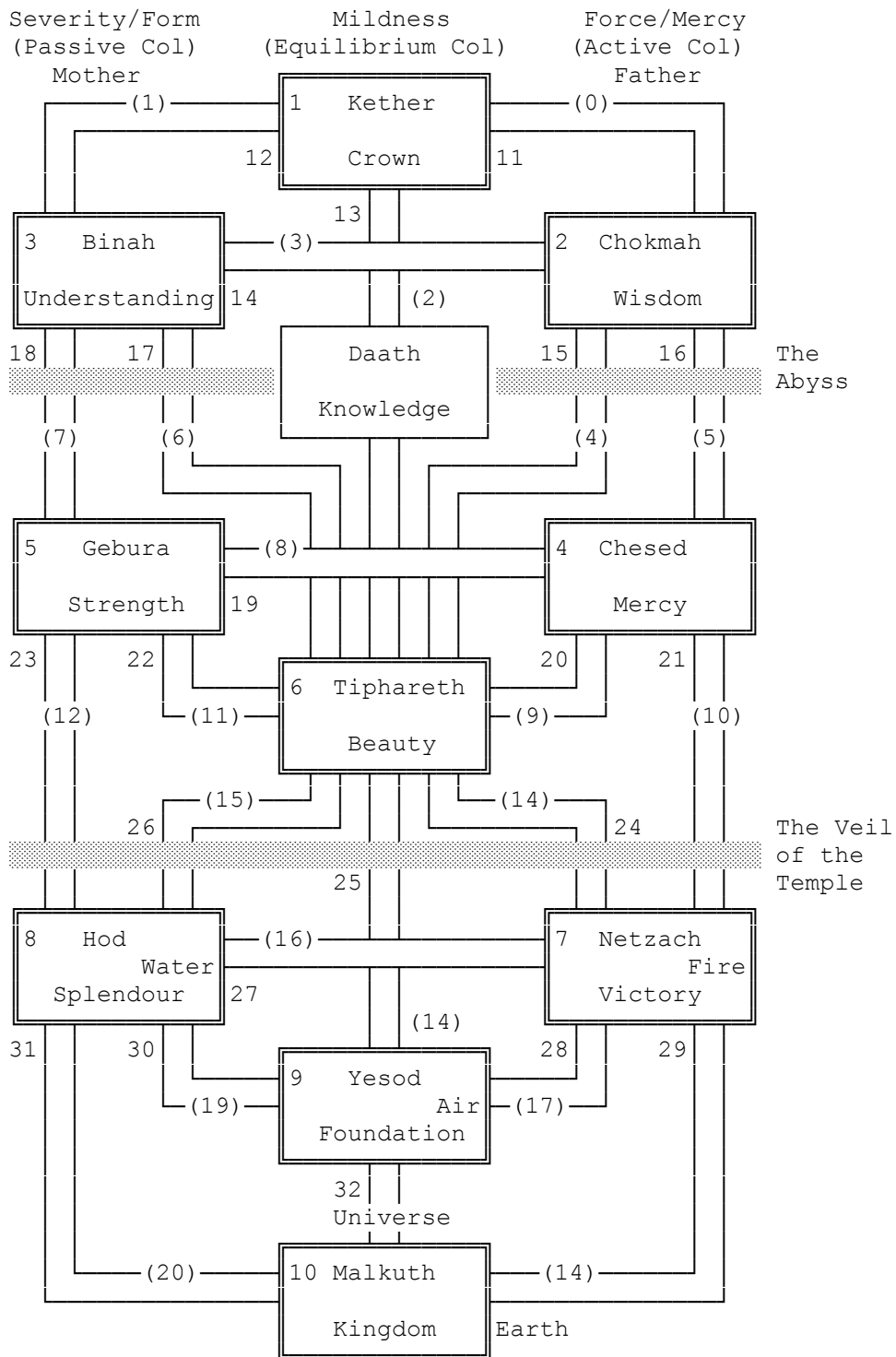

--()-

The Golden Dawn Tarot

THE TRUMPS

TRUMP - (0) - THE FOOL

Path 11, Card 0.

GENERAL: A naked child sits beneath a yellow rose tree (of Joy and Silence), he holds a grey wolf in leash, wisdom held in check by innocence. It is linked with the name of Kristna and Dionysus. The colours, pale yellow, blue and greenish yellow, suggesting an early spring dawn. The Hebrew letter is Aleph.

DIVINATORY MEANINGS: Spirituality, ideas.

REVERSED MEANINGS: It is too unstable to be good on the material plane, folly.

TRUMP - (1) - THE MAGICIAN

Path 12, Card 1.

GENERAL: The Magician or Adept is consecrating his magical instruments. He is reflected in the Intellect which stores knowledge and transmits it to Life. The number of the path 12 suggests the Zodiac belt. It is linked with Tahuti and Hermes. The colours yellow, violet, grey and indigo indicate the mysterious astral light around the Adept. The letter is Bes.

DIVINATORY MEANINGS: Skill, wisdom, adaptation particularly in occult spheres.

REVERSED MEANINGS: Craft and cunning.

TRUMP - (2) - THE HIGH PRIESTESS

Path 13, Card 2.

GENERAL: The High Priestess is the great feminine principle controlling the ultimate source of life, gathering the energising forces and keeping them solvent until their time of release. She rules the path from Kether to Tiphareth. Her colours are pale blue, darkening into sky blue, silver, with touches of flame and orange. The letter is Gimel.

DIVINATORY MEANINGS: Increase, change, alteration.

REVERSED MEANINGS: Decrease and change for the worse. Generally representing a religious tendency and orthodoxy; compare with XVIII.

TRUMP - (3) - THE EMPRESS

Path 14, Card 3.

GENERAL: The Empress is the creative side of nature as in the Egyptian trilogy - Isis, Hathor and Nephthys and their symbols respectively the crescent, full moon and gibbous moon. The Positive feminine is the force indicated. It is the door to the inner mysteries. The colours are emerald sky blue, blue green and cerise or rose pink. The letter is Daleth.

DIVINATORY MEANINGS: Success, beauty, happiness, pleasure.

REVERSED MEANINGS: Dissipation and black magic.

TRUMP - (4) - THE EMPEROR

Path 15, Card 4.

GENERAL: The Emperor is the doer and indicates by various degrees of red the great energizing forces. Note that all red paths remain red although varying in shades in all planes. Aries is blood red and deep crimson red, vermilion or fiery red. He is not passionate and carries the forces of Mars in love and war. He is positive masculine force. The letter is Heh.

DIVINATORY MEANINGS: War, conquest, victory, strife.

REVERSED MEANINGS: These powers are contrary to wishes.

TRUMP - (5) - THE HIGH PRIEST

Path 16, Card 5.

GENERAL: The Hierophant or High Priest is the counterpart of II (THE HIGH PRIESTESS) and reflects the mystical aspect of the masculine. He is the Thinker. Taurus is the house of Venus and the exaltation of the moon. His colours vary considerably, red, orange, maroon, deep brown. Indicates interior power, contemplation. The letter is Vau.

DIVINATORY MEANINGS: Divine Wisdom, Teaching, the Prophet, Occult Wisdom, and the guardianship of the masters.

REVERSED MEANINGS: The antagonistic working of - Divine Wisdom, Teaching, the Prophet, Occult Wisdom, and the guardianship of the masters.

TRUMP - (6) - THE LOVERS

Path 17, Card 6.

GENERAL: The Lovers and Perseus rescuing Andromeda from the Dragon of Fear and the Waters of Stagnation. They illustrate the impact of inspiration on intuition, giving liberation and illumination. The colours are orange, violet, purplish grey. The letter is Zayin.

DIVINATORY MEANINGS: Sympathetic understanding, inspiration and power resulting therefrom.

REVERSED MEANINGS: These qualities are reduced or negative.

TRUMP - (7) - THE CHARIOT

Path 18, Card 7.

The Chariot represents the spirit of man controlling his lower principles, soul and body, passing through the astral plane to the higher spheres. It shows the sublimation of the Psyche. The colours are amber, silver grey, blue grey, and blue violet of the night sky. The letter is Cheth.

DIVINATORY MEANINGS: Victory, Success, Health, Triumph.

REVERSED MEANINGS: Un-enduring or temporary success.

TRUMP - (8) - STRENGTH

Path 19, Card 8.

GENERAL: Strength represents the mastery of the lower by the higher. The Soul with her feet on earth holds in check the passions. A dark veil is around her head and body. The colours are greenish yellow, yellowish grey and reddish amber, deep rose gives a contrast. The letter is Teth.

DIVINATORY MEANINGS: Fortitude, Strength and courage, Power as a starting factor.

REVERSED MEANINGS: Obstinacy.

TRUMP - (9) - HERMIT

Path 20, Card 9.

GENERAL: The Hermit or Prophet is a man wrapped in a hood and mantle carrying a lantern to light the Path, and a staff to support his footsteps. He is the Seeker and Pilgrim Soul. His vestments are the brown of earth, the delicate yellow greens, and bluish greens of spring. The letter is Yod. Together with the Hierophant and Magician these cards are the three Magi.

DIVINATORY MEANINGS: Prudence, Divine Wisdom in the active sense as compared with the Lovers.

REVERSED MEANINGS: The card carries a bad influence.

TRUMP - (10) - THE WHEEL OF FORTUNE

Path 21, Card 10.

GENERAL: The Wheel of Life or Fortune presided over by the Cynocephalus below and the Sphinx above is the Riddle which can only be solved by attaining liberation. It is the revolution of the Zodiac, experience and progress, under the influence of Light and Darkness. The basic colours are blue, violet, deep purple and blue speckled with yellow. The Zodiac spheres are in the colours of the Spectrum, the ape as those of Malkuth, the sphinx in black and the primary colours. The letter is Kaph.

DIVINATORY MEANINGS: Good fortune and happiness according to the aspects.

REVERSED MEANINGS: Bad fortune and unhappiness according to the aspects.

TRUMP - (11) - JUSTICE

Path 22, Card 11.

GENERAL: Justice as opposed to love illustrated by Nephthys, the twin sister of Isis who is the third aspect of the Moon. The colours are green clothes, but a colder colour than the pure emerald of Isis, the other colours are blue, blue green and pale green. The letter is Lamed.

DIVINATORY MEANINGS: Balance and Eternal Justice, arrested force; compared with VIII (STRENGTH).

REVERSED MEANINGS: These properties are reduced.

TRUMP - (12) - THE HANGED MAN

Path 23, Card 12.

GENERAL: The Hanged Man is the sacrifice, the sublimation of the lower man by submergence of the higher. The descent of spirit into Matter illustrates the incarnation of God in Man. The colours are deep blue, white and black mixed (not grey), olive, green and greenish fawn. The letter is Mem.

DIVINATORY MEANINGS: Punishment, loss, involuntary sacrifice.

REVERSED MEANINGS: Suffering generally.

TRUMP - (13) - DEATH

Path 24, Card 13.

GENERAL: Death is the transmuting power of the Spirit from above working downwards. The skeleton survives the destruction of time, suggests the evolutionary changes which leave the Spirit relatively unchanged. The colours are blue-green, dark and light, orange and red-orange. The letter is Nun.

DIVINATORY MEANINGS: Transformation, time, involuntary change.

REVERSED MEANINGS: Death and destruction.

TRUMP - (14) - TEMPERANCE

Path 25, Card 14.

GENERAL: Temperance sums up the equilibrium in the arrow of Sagittarius, which clears its way by the impetus given by the bow. It requires the balance of Fire and Water (Shin and Qoph) controlled by the restrictive power of Saturn, and the active energies of Mars to initiate their impelling force. These are shown by the figure standing between Earth and Water, holding two jars with streams of living water, and the volcano in the distance. The colours are bright-blue, blue grey, slate blue and lilac grey. The letter is Samekh.

DIVINATORY MEANINGS: Material action; combination of forces, realization. For good or evil according to aspect.

REVERSED MEANINGS: Material action; combination of forces, realization. For good or evil according to aspect.

TRUMP - (15) - DEVIL

Path 26, Card 15.

GENERAL: The Devil indicates the lower nature of man as indicated by the chains on the smaller figures and the bestial nature of their lower limbs. The lower nature of man hates the transmitting process which is necessary to preserve continuity and stabilize the life force. This card should be studied in connection with XIII as they indicate the two great controlling forces of the universe, destructive and reproductive, centrifugal and centripetal, dynamic and static. The colours are indigo, livid brown, golden brown and grey. The letter is Ayin.

DIVINATORY MEANINGS: Material force, temptation, materiality.

REVERSED MEANINGS: Obsession and worldly obstacles.

TRUMP - (16) - THE TOWER

Path 27, Card 16.

The Tower struck by lightning suggests revolution instead of transmutation and sublimation. The destructive and powerful force ejects those who try to abandon themselves to ease and tradition. The colours are red in various shades, thrown into relief with shades of green. Compare with Emperor.

DIVINATORY MEANINGS: Courage, war, fighting, ambition.

REVERSED MEANINGS: Danger, ruin, destruction.

TRUMP - (17) - THE STAR

Path 28, Card 17.

GENERAL: The Star is the seven pointed star of Venus shining over the Waters of Aquarius. It is the guarding force of love illuminating the soul in human bondage. The dove of Spirit hovers over the Fire of Knowledge, and on the other side is the Tree of Life. The colours of dawn are amethyst, pale grey, fawn, dove and white with pale yellow of the star.

DIVINATORY MEANINGS: Unexpected help, faith and hope.

REVERSED MEANINGS: Dreamers and deception.

TRUMP - (18) - THE MOON

Path 29, Card 18.

GENERAL: The Moon is the path of blood, tears and sweat, in which weakness and fear must be overcome. The river is the troubled waters of Night, the Crayfish is similar to the Scarab beetle. From the waters' edge leads a dark path of toil, and possible failure. The threatening watchdogs intimidate the travellers, while in the distance are fortresses on the hills further guarding the way to attainment. The colours are dark crimson, reddish brown, brownish crimson and plum; these are contrasted by faint greens and yellows.

DIVINATORY MEANINGS: Voluntary change in contrast to XIII (DEATH), dissatisfaction.

REVERSED MEANINGS: Error, deception, lying.

TRUMP - (19) - THE SUN

Path 30, Card 19.

The Sun with its fiery rays may melt the waxen wings of the Icarus urged by Ambition and Curiosity. But the Pilgrim protected by an encircling wall may approach the Light with humility and absorb warmth and vitality to fit him for the coming struggle. The Watery Paths of probation are balanced by the Fiery path of Temptation and Decision. The colours are clear orange, golden yellow, amber flecked with red and the blue and purple as contrast. The sombre colours of Aquarius and Pisces opposing the flaring hues of the Sun and Fire.

DIVINATORY MEANINGS: Riches, glory, gain.

REVERSED MEANINGS: Display, arrogance and vanity.

TRUMP - (20) - JUDGEMENT

Path 31, Card 20.

GENERAL: The Last Judgement shows the cosmic concentrating on the pilgrim from all sides. Judgement is pronounced. Lazarus cannot emerge from the Sepulchre till the voice cries "Come Forth". Man himself is helpless, the impulse to ascend must come from above. It is only by this impulse that he can transcend the tomb, cast aside his desire attractions, and become one with the source of life itself.

DIVINATORY MEANINGS: Judgement, Final decision, aspects modify the nature of determination of the matter.

REVERSED MEANINGS: Judgement, Final decision, aspects modify the nature of determination of the matter.

TRUMP - (21) - THE UNIVERSE

Path 32, Card 21.

GENERAL: The Universe is represented and not the world. To the ancients Saturn passing through his spiral path in the Zodiac represented the confines of the Solar System. They had no knowledge of Uranus, Neptune or Pluto. The white gleam of the stars shining in the dark has the misty figure of Aimah Elohim in the midst. This card may be taken as the synthesis of the whole Tarot. If the central figure be Hathor, Athor or Ator instead of Isis the hidden anagram can be interpreted as follows; ORAT - many prays. ATOR - to the Great Mother. TARO - who turns. ROTA - the Wheel of Life and Death.

DIVINATORY MEANINGS: Synthesis, The Matter itself, World, Kingdom and this depends on its aspects more than the other cards.

REVERSED MEANINGS: Synthesis, The Matter itself, World, Kingdom and this depends on its aspects more than the other cards.

NOTE: The Trumps (8) and (11)

The trumps (8) and (11), carrying the correspondences of Leo and Libra, were transposed in the older cards, revolving on the pivot of Pisces. Crowley also transposed IV and XVII. He did this on the authority of Verse 57 of Chapter 1 of the Book of the Law. This only appears once in 777 (revised) and once in his Book of Thoth.

--()--

THE FOUR ACES

INTRODUCTION: The Four ACES represent the force of the spirit acting in, and binding together the four scales of each element in the Kether of each. Each one has an angelic hand issuing from a cloud which represents the Radical or Root-force. They are said to be placed around the North Pole to govern its revolution and connecting the Higher with the Material Plane.

ACE OF PENTACLES

GENERAL: The hand should hold a rose tree branch on which rests a large Pentacle formed in five concentric circles. The centre is white with a red Greek cross (composed of 13 squares). From the centre emerge 12 radii suggestive of the Zodiac divisions of the Heavens. Resting above is a smaller circle, surmounted by a Maltese Cross with two wings at the sides.

DIVINATORY MEANINGS: Materiality in the sense of either good or evil. It is mainly illusionary and indicates gain, labour, power and work. It is the Root of the Powers of Earth.

ACE OF CUPS

GENERAL: The radiant hand supports a cup from which issues a fountain of pure water which falls into the calm water below in which grow Lotus and Water Lilies. The great letter Heh of the supernal Mother (sometimes M) should be traced in the spray.

DIVINATORY MEANINGS: Fertility, Productiveness, Happiness, Beauty and Pleasure. It is the Root of the Powers of Water.

ACE OF WANDS

GENERAL: The issuing hand holds a heavy club with three branches surrounded by leaping flames or Yods. The whole is a flaming torch.

DIVINATORY MEANINGS: Natural as opposed to Invoked force, vigour, energy strength and rush. It is the Root of the Powers of fire.

ACE OF SWORDS

GENERAL: The angelic hand supports a sword on which is impaled a celestial crown from which descend on the left the Palm of suffering and on the right the branch of peace. Six Vaus fall from the point.

DIVINATORY MEANINGS: Invoked force as opposed to natural force, upwards representing spiritual brightness, justice and strength in a whirling force.

REVERSED MEANINGS: It is the invocation of evil, wrath, punishment and affliction. It is the Root of the Powers of Air.

--()--

THE SIXTEEN COURT CARDS

INTRODUCTION: The Four KINGS should be seated on steeds and clothed in armour to represent the Yod forces in each suit. They represent the swift and violent unsustained force of the radix or commencement of the Material Forces containing all others. Therefore is a knowledge of the King Scale is necessary to all magical working.

INTRODUCTION: The Four QUEENS seated on Thrones represent the Heh forces in each suit. They represent the mother, or birth of material force, steady and unshaken, enduring but not rapid. They should also be clothed in armour.

INTRODUCTION: The Four KNIGHTS or PRINCES should be seated in chariots representing the Vau forces realizing the influence of both scales of force - the King and Queen. Its power is illusionary unless set in motion by the Father and Mother.

INTRODUCTION: The Four PAGES, or PRINCESSES, or KNAVES, standing firmly by themselves, represent the forces of Heh final - completing the other scales. The power is at once violent and permanent - mainly material, but is also the throne of the Forces of the Spirit.

--()--

KING OF PENTACLES

GENERAL: He is a winged figure in a chariot drawn by a bull. He has a winged bull's head as a crest, beneath is a flower-decked band. A golden orb held downwards is in one hand, in the other is a wand with an orb and cross on top.

DIVINATORY MEANINGS: Increase in all things, consolidation, reliability.

REVERSED MEANINGS: Material, stupid, carnal. Slow to action in both. He is the Emperor of Gnomes and the Air of Earth.

QUEEN OF PENTACLES

GENERAL: She is a beautiful woman with dark hair, one side of her face is light the other in shadow. Her crest is a winged goat's head, and a goat is by her side. In one hand is a golden orb, in the other a wand surmounted by a cube.

DIVINATORY MEANINGS: Charming impetuosity, intelligence, open hearted, truthfulness, of many moods.

REVERSED MEANINGS: Foolish, changeable and undecided. She is the Queen of Gnomes and the Water of Earth.

KNIGHT OF PENTACLES

GENERAL: He is a dark winged warrior with winged helmet, he rides a light brown horse. His crest is a winged stag's head. Under the horse's feet is a field of ripe corn. In one hand he holds a pentacle in the other a wand with a hexagon on top.

DIVINATORY MEANINGS: Persistence and patience in material matters, clever and dull.

REVERSED MEANINGS: Jealousy and avariciousness. He is the King of Gnomes and the Fire of Earth.

PAGE OF PENTACLES

GENERAL: She is a strong beautiful figure standing in a flowered meadow. She has brown hair and a ram's head as a crest and wears a sheepskin coat. In one hand is a Pentacle, in the other a wand surmounted by a circular disc.

DIVINATORY MEANINGS: Courage benevolence, care, kindness.

REVERSED MEANINGS: Prodigal and wasteful. She is the Queen of Gnomes and the Earth of Earth.

--()--

KING OF CUPS

GENERAL: He is a winged figure, with a winged crown, seated on a chariot drawn by an eagle, on the wheel is the sign of the Scorpion, beneath the chariot are the calm waters of a lake. In one hand is a lotus and in the other a cup from which issues a serpent. He is the emperor of Undines and the Air of Water.

DIVINATORY MEANINGS: Crafty and artistic force in a violent way. Powerful for good or evil but tending towards the former if productive of power or wisdom.

REVERSED MEANINGS: He is evil and intensely merciless. He is the Emperor of Undines and the Air of Water.

QUEEN OF CUPS

GENERAL: She sits upon her throne under which is Rowing water, she is very beautiful and fair, her hand holds a lotus and beside her is an ibis. She holds a cup from which a crayfish emerges.

DIVINATORY MEANINGS: Imagination of the poetic kind, good natured and dreamy. Affected by outside influences is dependent on good or bad placing more than the other court cards. She is the Queen of Undines or Water of Water.

KNIGHT OF CUPS

GENERAL: He is a young warrior seated upon a white horse, on his helmet is a peacock, he holds a cup in his hand from which crawls a crab. The sea is underneath his steed.

DIVINATORY MEANINGS: Indolence, sensuality but unenthusiastic.

REVERSED MEANINGS: Idle and untruthful. He is the King of Undines and the Fire of Water.

PAGE OF CUPS

GENERAL: She is standing on a sea with a dolphin on her right, she has a swan on her helmet and holds a cup in one hand from which a turtle issues, in the other is a lotus.

DIVINATORY MEANINGS: Sweetness, kindness and gentleness, dreamy but courageous.

REVERSED MEANINGS: She can be luxurious and selfish. She is the Empress of Undines and the Earth of Water.

--()--

KING OF WANDS

GENERAL: He wears a golden winged crown. His chariot is drawn by a lion, he bears a torch and flames are beneath the chariot. He is the ruler of Salamanders, and the Air of Fire.

DIVINATORY MEANINGS: Swift, strong and hasty action, yet just and generous.

REVERSED MEANINGS: Cruel, intolerant and prejudiced.

QUEEN OF WANDS

GENERAL: She has long red gold hair, seated on a throne with flames beneath, at her side is a couchant leopard and she bears a long wand with a heavy conical head.

DIVINATORY MEANINGS: A steady force, adaptability, power to command. Kind and generous if not opposed.

REVERSED MEANINGS: Domineering, revengeful and obstinate. She is the Queen of Salamanders, and the Water of Fire.

KNIGHT OF WANDS

GENERAL: He is a winged warrior on a black horse with a flowing tail, wearing a winged helmet, he holds a club with a flaming end.

DIVINATORY MEANINGS: Activity, generous sudden and impetuous action. He is the King of Salamanders, and the Fire of Fire.

PAGE OF WANDS

GENERAL: She is a strong and beautiful woman, wearing a plumed helmet, surmounted by a tiger's head. Her right hand rests on a brazen altar, in her left she holds a flaming wand.

DIVINATORY MEANINGS: Beauty, sudden force, desire for love, power, or revenge.

REVERSED MEANINGS: Superficial, unstable, domineering and cruel. She is the Empress of Salamanders, and the Earth of Fire.

--()---

KING OF SWORDS

GENERAL: He is a winged figure with a winged crown in a chariot drawn by Fairies, their wings carry pentagrams and their wands have the same symbol on top. Grey clouds are beneath the chariot. He has a sword in one hand and a sickle in the other. He rules with the sword and slays with a sickle.

DIVINATORY MEANINGS: Firmness, ideas, designs, suspicions, alpha and omega, who creates as fast as he slays.

REVERSED MEANINGS: He is malicious, obstinate and unreliable. He is the Emperor of Sylphs and the Air of Air.

QUEEN OF SWORDS

GENERAL: She is graceful with waving hair, with a crest like a winged child's head or Kerub, a drawn sword in one hand and a severed bearded head of a man in the other.

DIVINATORY MEANINGS: Keen observation, speed, confidence, fond of dancing and similar amusements.

REVERSED MEANINGS: Unreliable, deceitful, cruel, sly but with a good exterior. She is the Queen of Sylphs and the Water of Air.

KNIGHT OF SWORDS

GENERAL: He is winged on a brown steed and wears a winged helmet. His crest is a six pointed star. He carries a drawn sword and underneath his horse are dark clouds.

DIVINATORY MEANINGS: Courage, skill, fierceness and delicate activity inclined to domineer.

REVERSED MEANINGS: Deceitful, tyrannical and crafty. He is the King of Sylphs and the Fire of Air.

PAGE OF SWORDS

GENERAL: She wears as a crest the head of Medusa with serpent hair. She has one hand on a small silver altar with grey smoke arising but no fire, her other hand holds a sword. Beneath her feet are white Cirrus clouds.

DIVINATORY MEANINGS: Wisdom, grace and dexterity combined with strength.

REVERSED MEANINGS: She is frivolous and cunning. She is the Empress of Sylphs and the Earth of Air.

--()--

THE SUIT OF PENTACLES

TWO OF PENTACLES

GENERAL: The pentacles are united by a gold and green snake like the figure eight or sign of infinity. A radiant hand grasps the centre which appears to be revolving. The symbols are Jupiter and Capricorn.

DIVINATORY MEANINGS: Visits to friends, pleasant change, alternating loss and gain, fortunate for journeys.

REVERSED MEANINGS: Wavering, inconsistent, wandering. The Lord of Harmonious Change. Jupiter in Capricorn 1°-10° and the Chokmah of Heh final.

THREE OF PENTACLES

GENERAL: The pentacles are arranged in a triangle with a branch of a rose tree and two white birds surmounting the upper circle. Above and below are the symbols of Mars and Capricorn.

DIVINATORY MEANINGS: Business, employment, commercial deals. Influence, gain in deals, increase of material things, creative work, commencement of project.

REVERSED MEANINGS: Narrow, keen to gain, prejudiced, seeking the impossible. The Lord of Material Works, Mars in Capricorn 10°-20° and the Binah Heh final.

FOUR OF PENTACLES

GENERAL: The pentacles form a square, with the Sun and Capricorn above and below. A hand holds a branch of a rose tree, no flowers except one blown white bloom in centre. The signs of Sun and Capricorn in the usual positions.

DIVINATORY MEANINGS: Gain in money or influence, success, power.

REVERSED MEANINGS: Prejudiced, suspicion and discontent. The Lord of Earthly Power, Sun in Capricorn 20°-30° and the Chesed of Heh final.

FIVE OF PENTACLES

GENERAL: The pentacles are similar to the ace, with a hand holding a rose tree from which all flowers and buds have fallen. The Symbols are Mercury and Taurus.

DIVINATORY MEANINGS: Loss of money or job, trouble about material things, poverty.

REVERSED MEANINGS: Makes conditions worse. The Lord of Material Troubles. Mercury in Taurus 1°-10° and the Geburah of Heh final.

SIX OF PENTACLES

GENERAL: The pentacles are arranged in a column of twos, with a hand holding a branch of white roses which touch the pentacles. The Symbols are Luna and Taurus.

DIVINATORY MEANINGS: Prosperity in business, success in material matters, power, rank, influence, success.

REVERSED MEANINGS: Prodigal, indolent and purse-proud. The Lord of Material Success, Moon in Taurus 10°-20° and the Tiphareth of Heh final.

SEVEN OF PENTACLES

GENERAL: The pentacles are arranged as a square with an inverted triangle above. A hand projects from a black cloud holding a rose branch to which the pentacles are attached. The Symbols are Saturn and Taurus.

DIVINATORY MEANINGS: Unprofitable speculation, and difficulty in employment, much work for little gain. Promises of Unfulfilled success. Disappointment.

REVERSED MEANINGS: The difficulties are increased. The Lord of Success Unfulfilled. Saturn in Taurus 20°-30° and the Netzach of Heh final.

EIGHT OF PENTACLES

GENERAL: The pentacles are arranged in a column of twos. The hand issues from a cloud, holds a rose branch, the flowers of which touch only the lower four pentacles. The Pentacles are similar to the aces but without the wings and cross. The Symbols are Sun and Virgo.

DIVINATORY MEANINGS: Skill, cunning prudence, over careful in small things at the expense of the great.

REVERSED MEANINGS: Mean, lacking in enterprise, avaricious. The Lord of Prudence, Sun in Virgo 1°-10° and the Hod of Heh final.

NINE OF PENTACLES

GENERAL: The pentacles are arranged as two squares, at the top and bottom of the card, with one at the centre. A hand holds rose branch with nine white flowers. The signs are Venus and Virgo.

DIVINATORY MEANINGS: Increase of goods, inheritance, completion of material gain.

REVERSED MEANINGS: Theft, knavery, covetousness. The Lord of Material gain, Venus in Virgo 10°-20° and the Yesod of Heh final.

TEN OF PENTACLES

GENERAL: The pentacles are touched by roses on a branch held by a hand as before. The Symbols are Mercury and Virgo.

DIVINATORY MEANINGS: Riches and Wealth, completion of material gain and fortune.

REVERSED MEANINGS: Old age, slothfulness, dullness of mind. The Lord of Wealth, Mercury in Virgo 20°-30° and the Malkuth of Heh final.

--()--

THE SUIT OF CUPS

TWO OF CUPS

GENERAL: On the lower part of the card is water with lotus flowers arising, one nearly to the top of the card. Crossed on the stem below are two dolphins, gold and silver. Water overflows from the lotus bloom into two cups which in turn overflow to the water below, cascading off the dolphin's backs as it falls. Above and below are the signs of Venus and Cancer.

DIVINATORY MEANINGS: Harmony of union, marriage, pleasure, mutual joy.

REVERSED MEANINGS: Disharmony, dissipation, folly. The Lord of Fire, Venus in Cancer 1°-10° and the Chokmah of Heh.

THREE OF CUPS

GENERAL: A hand holds a group of Lotuses. Water falls into the top cup from one bloom and overflows into the two cups placed below, and then to the lower part of the card. The signs are of Mercury and Cancer.

DIVINATORY MEANINGS: Abundance, plenty, pleasure and good luck.

REVERSED MEANINGS: The same fortunes but of very temporary nature. It is the Lord of Abundance, Mercury in Cancer 10°-20° and the Binah of Heh.

FOUR OF CUPS

GENERAL: Two above and two below, with water and lotuses as before. Two leaves are between the cups making a cross with the stem. The signs are Luna and Cancer.

Signifies: Success or pleasure nearing completion, a static period in a project.

REVERSED MEANINGS: Injustice, pleasure mixed with anxiety. It is the Lord of Blended Pleasure, Moon in Cancer 20°-30° and the Chesed of Heh.

FIVE OF CUPS

GENERAL: Lotuses are now leaves only with flowers falling and no buds. Neither is there any water in the cups. The signs are Mars and Scorpio.

DIVINATORY MEANINGS: Disappointments in love, marriage, loss of friendship, deceit.

REVERSED MEANINGS: All these characters are amplified. Lord of Loss in Pleasure, Mars in Scorpio 1°-10° and the Geburah of Heh.

SIX OF CUPS

GENERAL: Six flowers bend over six cups, into which they pour glistening water. The symbols are Sun and Scorpio.

DIVINATORY MEANINGS: Beginning of success, increase, gain or pleasure.

REVERSED MEANINGS: Defective knowledge, vanity and thankless presumption. The Lord of Pleasure, Sun in Scorpio, 10°-20° and the Tiphareth of Heh.

SEVEN OF CUPS

GENERAL: Seven Cups are empty and are arranged as shown. The lotus arises from the lower cup, and each flower overhangs a cup. The symbols are Venus and Scorpio.

DIVINATORY MEANINGS: Promises unfilled, error, inability to retain success.

REVERSED MEANINGS: Lust, drunkenness, wrath, selfish dissipation, deception in love and friendship. The Lord of Illusionary Success, Venus in Scorpio 20°-30° and the Netzach of Heh.

EIGHT OF CUPS

GENERAL: A hand holds a stem of Lotuses. The cups are arranged as shown. There are but two flowers which are pouring water into the centre cups. The other cups are empty. The signs are Saturn and Pisces.

DIVINATORY MEANINGS: Temporary Success, things thrown away as soon as acquired.

REVERSED MEANINGS: Misery, instability, indolence repining without cause. The signs above and below are Saturn and Pisces. The Lord of Abandoned Success. Saturn in Pisces 1°-10° and the Hod of Heh.

NINE OF CUPS

GENERAL: The cups are arranged in three rows, a hand issuing from a cloud holds a bunch of Lotuses one over each cup. Water pours into each cup which are full and running over. The symbols are Jupiter and Pisces.

DIVINATORY MEANINGS: Complete Success, wishes fulfilled, and happiness to perfection.

REVERSED MEANINGS: Vanity, conceit, selfish and too much self-assumption. The Lord of Material Happiness. Jupiter in Pisces 10°-20° the Yesod of Heh.

TEN OF CUPS

GENERAL: The arrangement is similar to the nine of cups with one extra cup on top. The symbols are Mars and Pisces.

DIVINATORY MEANINGS: Completion of good fortune, matters arranged as desired, permanent lasting success. REVERSED MEANINGS dissipation, debauchery, wantonness. Lord of Perfected Success, Mars in Pisces 20°-30° and the Malkuth of Heh.

--()--

THE SUIT OF WANDS

TWO OF WANDS

GENERAL: A hand grasps two large crossed wands, the junction produces flames. Above and below are two small wands on which are the symbols of Mars and Aries, also with flames rising from them.

DIVINATORY MEANINGS: Strength, fierceness, authority, resolution.

REVERSED MEANINGS: It is domination, unforgiving, obstinate, Lord of Dominion, Mars in Aries 1°-10° and the Chokmah of Yod.

THREE OF WANDS

GENERAL: Two crossed wands and one upright held by a hand. Flames issue from the junction. Above and below are the Sun and Aries.

DIVINATORY MEANINGS: Realization, completion, success and wealth.

REVERSED MEANINGS: Arrogance, rudeness and insolence, conceit and obstinacy. Lord of Established Strength. Sun in Aries 10°-20°, and the Binah of Yod.

FOUR OF WANDS

GENERAL: Two clasped hands holding four crossed wands with flames at the junction. Above and below are two small wands with the signs of Venus and Aries.

DIVINATORY MEANINGS: Completion, rest after labour, reasoning from knowledge.

REVERSED MEANINGS: Unreliable, hurried action, unready and uncertain. Lord of Perfected Work. Venus in Aries 20°-30° and the Chesed of Yod.

FIVE OF WANDS

GENERAL: Two clasped hands hold four crossed wands together with one upright. Above is the Saturn symbol and below is Leo.

DIVINATORY MEANINGS: Quarrelling and fighting, strife.

REVERSED MEANINGS: Violence, rashness, cruelty, lust. Lord of Strife. Saturn in Leo 1°-10° and the Geburah of Yod.

SIX OF WANDS

GENERAL: Two clasped hands hold six wands in two groups of three. Above and below are two wands of Jupiter and Leo. From the junction issue flames.

DIVINATORY MEANINGS: Gain, victory after strife, success after industry and energy. Sociability.

REVERSED MEANINGS: Insolence, pride. The Lord of Victory, Jupiter in Leo 10°-20° and the Tiphareth of Yod.

SEVEN OF WANDS

GENERAL: Two clasped hands holding six wands as before, the seventh wand is held by a third hand, crossing at the junction from which issue flames. Above and below are the symbols of Mars and Leo.

DIVINATORY MEANINGS: Courageous opposition, valour in small things, opposition, difficulties.

REVERSED MEANINGS: Quarrelling, ignorance, wrangling. Lord of Valour, Mars in Leo 20°-30° and the Netzach of Yod.

EIGHT OF WANDS

GENERAL: Four radiating hands clasp eight wands in two groups of four. Flames issue from the junctions, with the symbols of Mercury and Sagittarius above and below.

DIVINATORY MEANINGS: Swiftmess, boldness, courage, great force applied suddenly, quickly expended. Love of outdoors.

REVERSED MEANINGS: Untrustworthy, violent, oppressive, theft. Lord of Swiftmess, Mercury in Sagittarius 1°-10° the Hod of Yod.

NINE OF WANDS

GENERAL: Four hands holding eight wands crossed in fours with a fifth hand holding an upright wand crossing the junction from which flames issue. The symbols are Luna and Sagittarius, the former horizontally.

DIVINATORY MEANINGS: Steady and tremendous force. Success, victory preceded by apprehension, good health.

REVERSED MEANINGS: Obstinate, questioning doubt. Lord of Great Strength, Moon in Sagittarius 10°-20° and the Yesod of Yod.

TEN OF WANDS

GENERAL: Four hands as before, a fifth hand holds two wands which cross at the junction, flames as before.

DIVINATORY MEANINGS: Cruel force applied for material ends, self-sacrifice, sometimes failure in a project.

REVERSED MEANINGS: Speed in evil, slander, envy, motive, lying. The Lord of Oppression, Saturn in Sagittarius 20°-30° and the Malkuth of Yod.

--()--

THE SUIT OF SWORDS

TWO OF SWORDS

GENERAL: The swords are held crossed by a radiating hand, at the intersection is a five petalled rose emitting rays. At the top and bottom are two small daggers with the signs of Luna and Libra on the points.

DIVINATORY MEANINGS: Balance after strife. Pleasure after pain. Strength through suffering. Justice, quarrels made up.

REVERSED MEANINGS: Repetition or errors, talkative, injury through speech. The Lord of Peace Restored. Moon in Libra 1°-10° and the Chokmah of Vau.

THREE OF SWORDS

GENERAL: The swords are as before, but the centre sword has apart the rose and its petals fall, no rays issue from it. Above and below are the symbols Saturn and Libra.

DIVINATORY MEANINGS: Unhappiness, sorrow, tears, disruption: honesty in money matters.

REVERSED MEANINGS: Selfish and dissipated, deceitful, fun in evil pleasures. The Lord of Sorrow, Saturn in Libra 10°-20° and the Binah of Vau.

FOUR OF SWORDS

GENERAL: Two hands each hold two swords, the radiating rose is at the intersection. The symbols are Jupiter and Libra.

DIVINATORY MEANINGS: Recovery from sickness, change for the better, peace after struggle, ease and plenty.

REVERSED MEANINGS: May be modified by its context with other cards. Lord of Rest from Strife. Jupiter in Libra 20°-30° and the Chesed of Vau.

FIVE OF SWORDS

GENERAL: Two hands each holding three swords falling away from the centre sword which is held by a third hand as if it had separated them. The Rose petals are again torn apart and falling. The symbols are Venus and Aquarius.

DIVINATORY MEANINGS: Defeat, loss, spite, malice, trouble, poverty, slander and sorrow after gain.

REVERSED MEANINGS: These characteristics are accentuated. The Lord of Defeat, Venus in Aquarius 1°-10° and the Geburah of Vau.

SIX OF SWORDS

GENERAL: The swords are held by two hands with the rose at the cross in the centre. The symbols are Mercury and Aquarius.

DIVINATORY MEANINGS: Success after anxiety, patience, journey by water, work.

REVERSED MEANINGS: Selfishness, conceit, The Lord of Earned Success. Mercury in Aquarius 10°-20° and the Tipareth of Vau.

SEVEN OF SWORDS

GENERAL: The swords are as before, but the third hand holds a rose and a seventh sword in the centre. The points just touch.

DIVINATORY MEANINGS: Journey by land, partial success, not enough strength to complete the matter.

REVERSED MEANINGS: Fascinated by display, betrayal of confidences, vacillating, unreliable. The Lord of Unstable Effort. Moon in Aquarius 20°-30° and the Netzach of Vau.

EIGHT OF SWORDS

GENERAL: The swords are held by four hands, two in each and touching near the top of the card. The rose is again in the centre. The symbols are Jupiter and Gemini.

DIVINATORY MEANINGS: Generous in money matters, too much force applied to small matters, ignoring the main issue. Wisdom applied to unworthy ends.

REVERSED MEANINGS: Impulsive, narrow, restricted, a prison. The Lord of the Shortened Forces. Jupiter in Gemini 1°-10° and the Hod of Vau.

NINE OF SWORDS

GENERAL: The swords are as before, but a fifth hand holds the one sword upright in the centre, dividing the other swords into two groups. The rose is absent.

DIVINATORY MEANINGS: Oppression, hard work, lying, dishonesty, slander, cruelty.

REVERSED MEANINGS: Increases these characteristics. Lord of Despair and Cruelty, Mars in Gemini 10°-20° and the Yesod of Vau.

TEN OF SWORDS

GENERAL: The swords are as before, but two crossed swords are dividing the others into two groups. The symbols are Sun and Gemini.

DIVINATORY MEANINGS: Ruin, disruption, death, failure of plans.

REVERSED MEANINGS: Increases the power of evil. Lord of Ruin, Sun in Gemini 20°-30° and the Malkuth of Vau.

--()--

The Four Worlds

World	Jewish Tradition	Jewish Tradition	Veritas Tradition	Veritas Tradition	VeritasSephiroth
1	Azilut	Emanations	Atziluth	Archetypal or Emanation	1.
2	Beriah	Creations	Briah_	Creation	2, 3.
3	Yizerah	Formations	Yetzirah_	Formation	4, 5, 6, 7, 8, 9.
4	Asiyyah	Making	Assiah	Action	10.

--()---

The Tree of Life - 4 Veritas Worlds

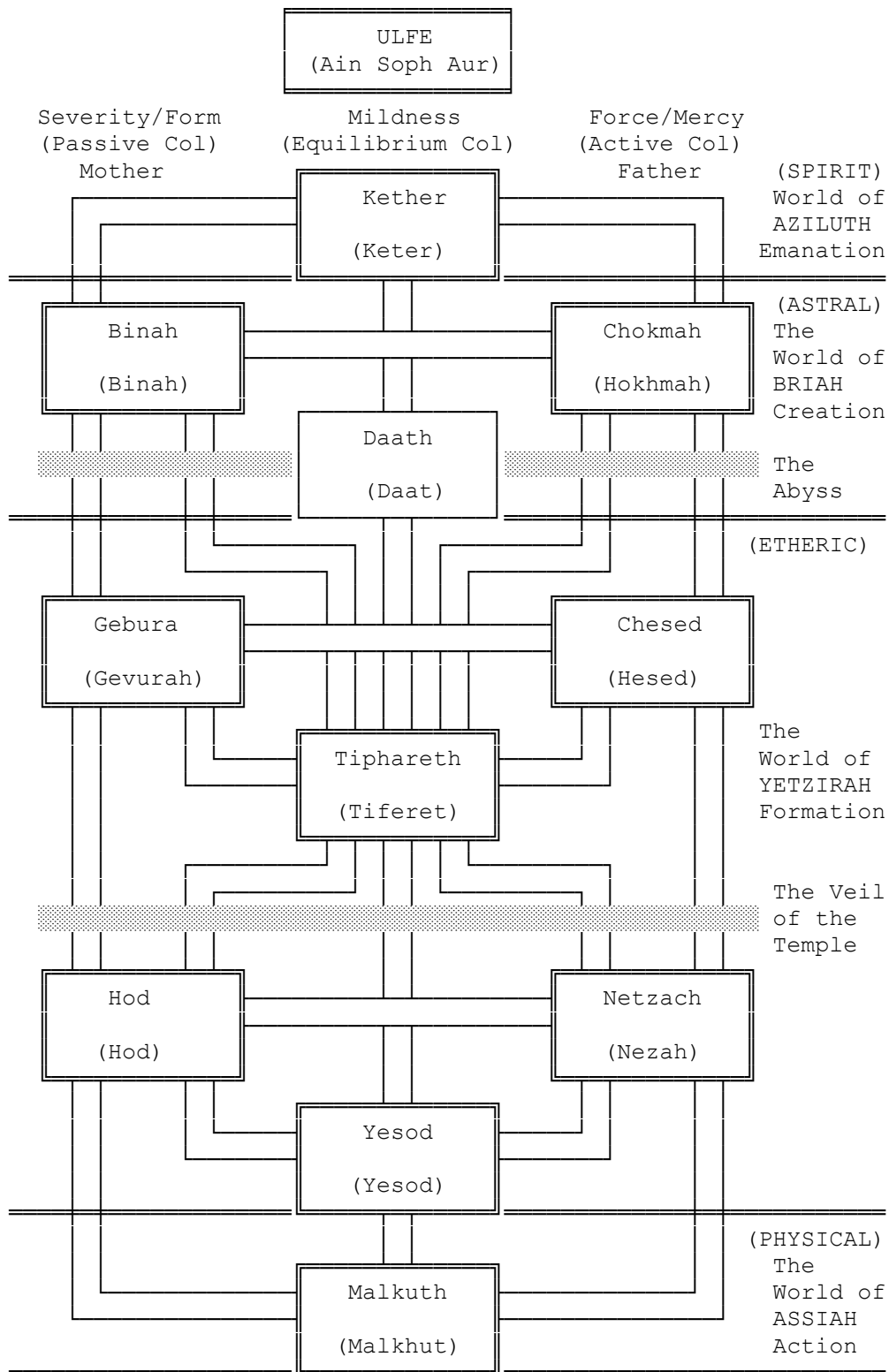

--()---

The Tree of Life - 4 Jewish Worlds

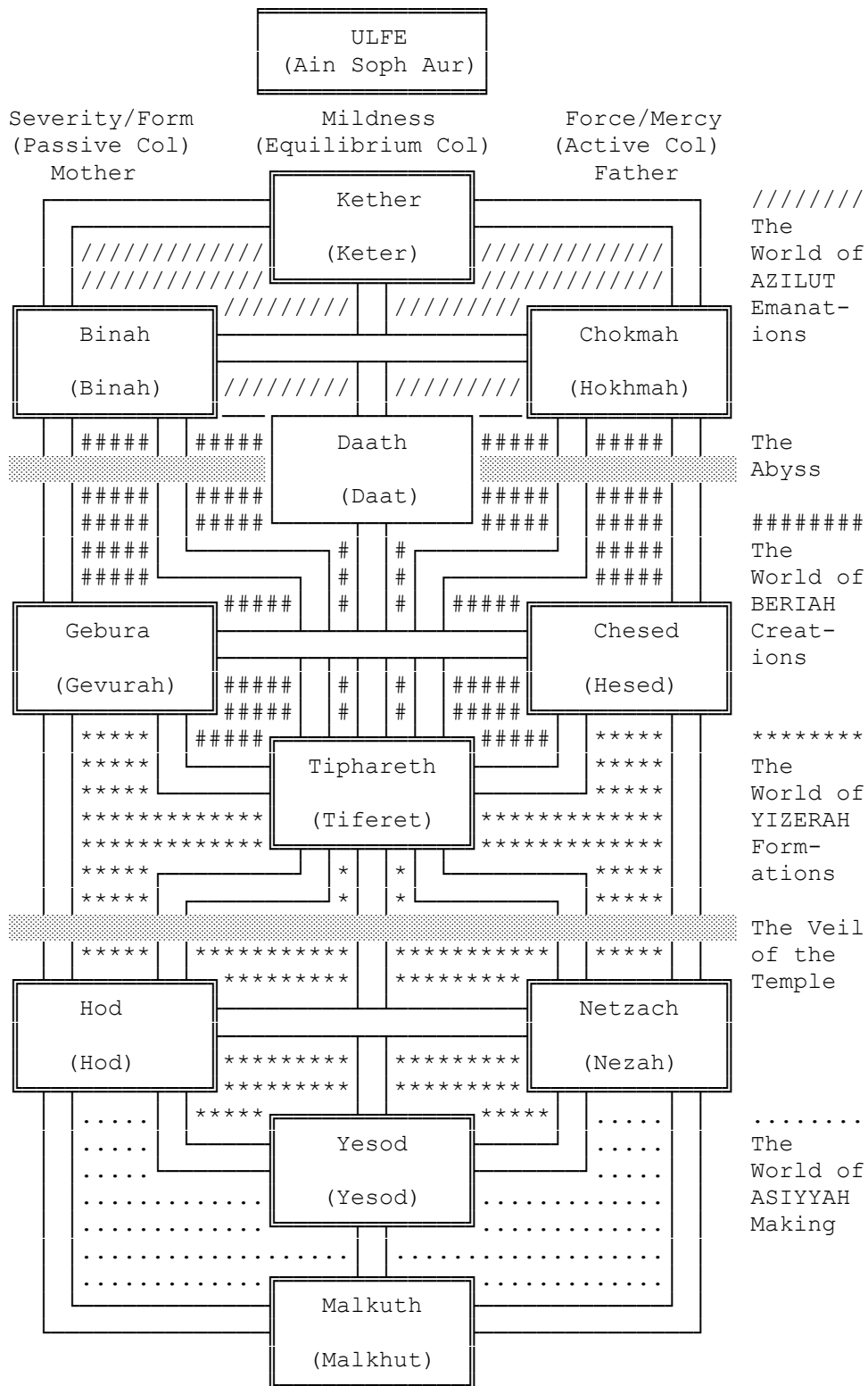

--()--

The Tree of Life - Lightning Flash

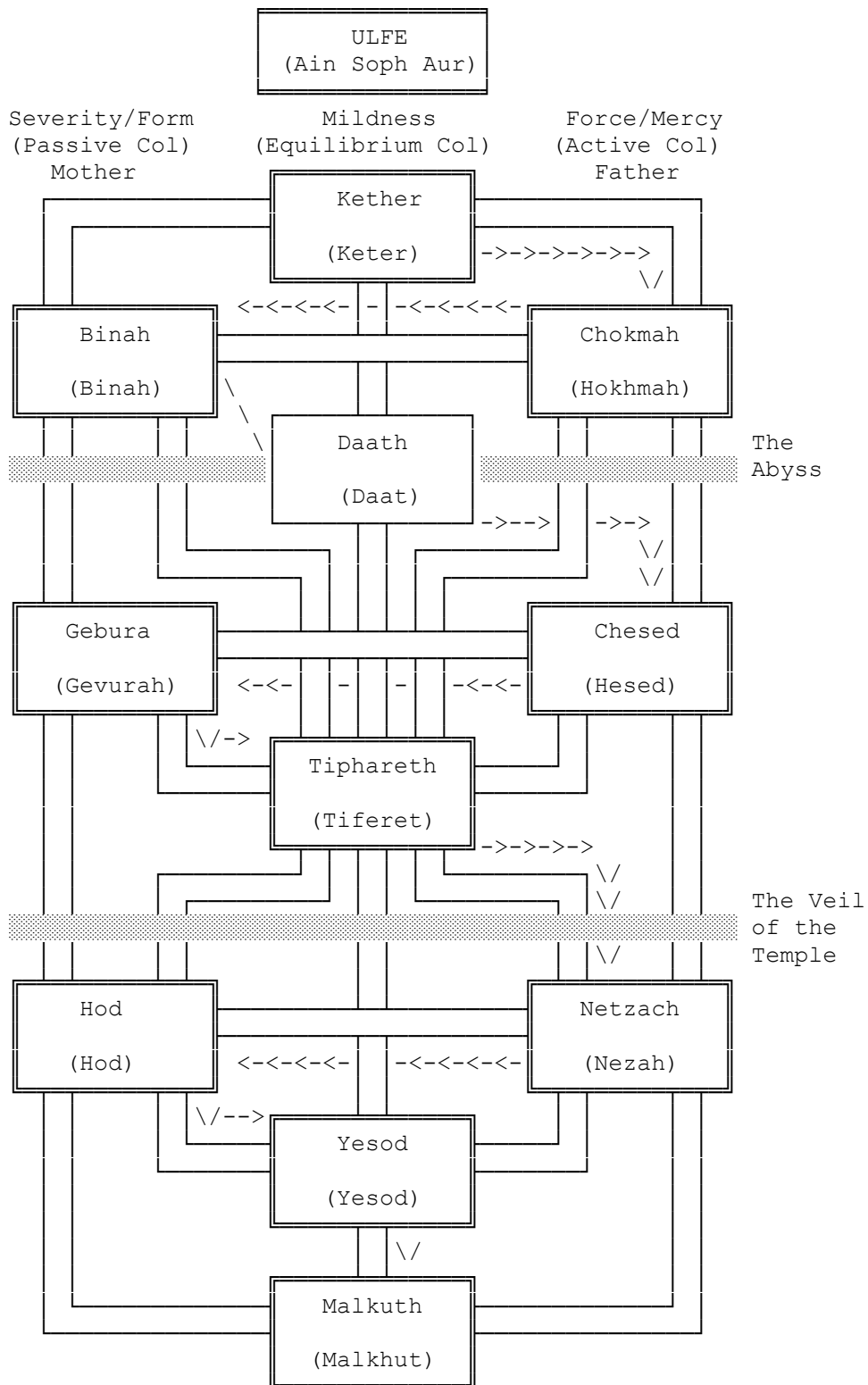

--()--

The Tree of Life - Astrology

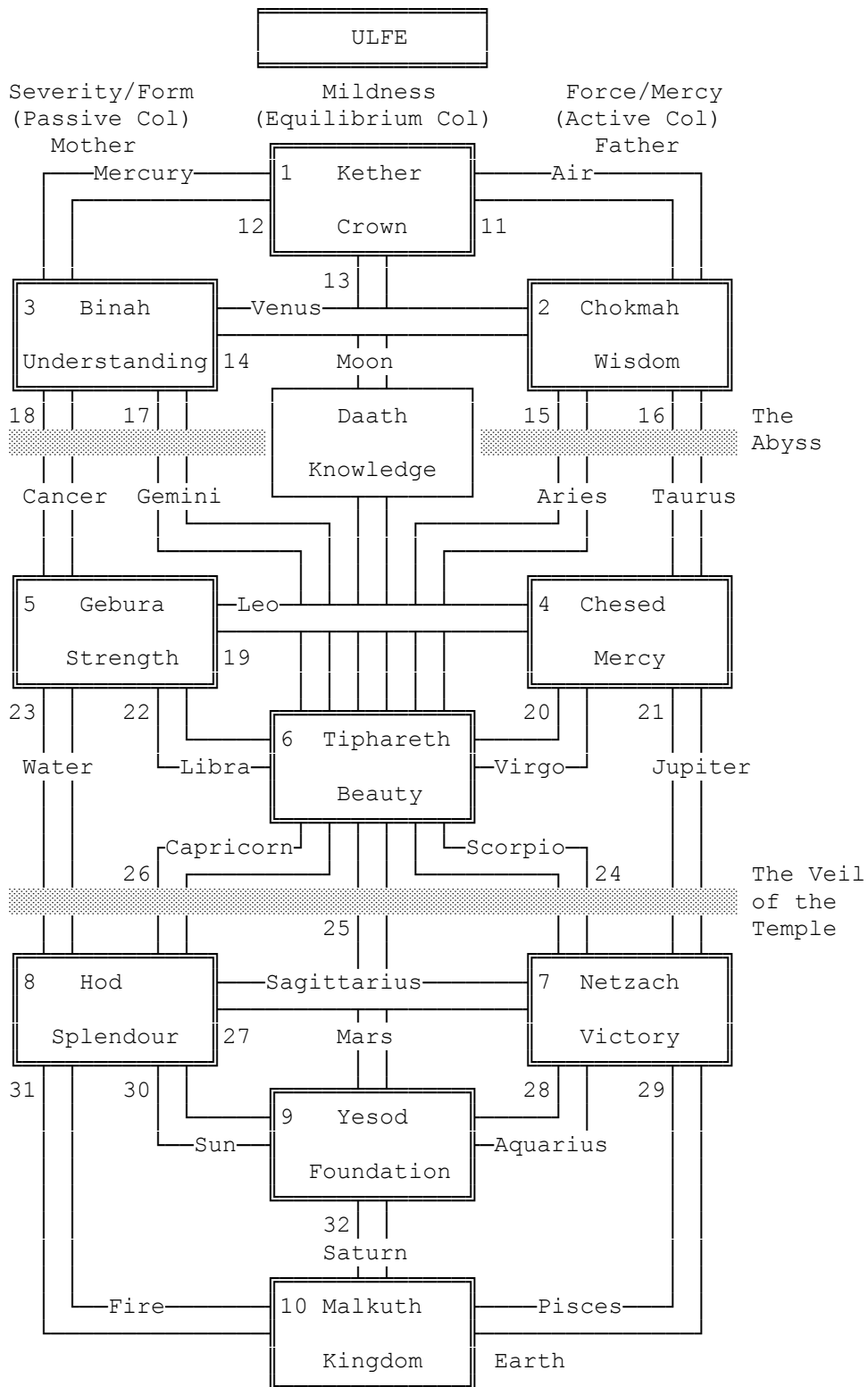

End

--()--

27102009/1